

Title	Research on Layered 3D Display System based on the combination of Transparent LCD and Traditional LCD
Sub Title	
Author	熊, 迪(Xiong, Di) 小木, 哲朗(Ogi, Tetsuro)
Publisher	慶應義塾大学大学院システムデザイン・マネジメント研究科
Publication year	2014
Jtitle	
JaLC DOI	
Abstract	
Notes	修士学位論文. 2014年度システムエンジニアリング学 第156号
Genre	Thesis or Dissertation
URL	https://koara.lib.keio.ac.jp/xoonips/modules/xoonips/detail.php?koara_id=KO40002001-00002014-0012

慶應義塾大学学術情報リポジトリ(KOARA)に掲載されているコンテンツの著作権は、それぞれの著作者、学会または出版社/発行者に帰属し、その権利は著作権法によって保護されています。引用にあたっては、著作権法を遵守してご利用ください。

The copyrights of content available on the Keio Associated Repository of Academic resources (KOARA) belong to the respective authors, academic societies, or publishers/issuers, and these rights are protected by the Japanese Copyright Act. When quoting the content, please follow the Japanese copyright act.

Master's Dissertation

2014

**Research on Layered 3D Display System
based on the combination of
Transparent LCD and Traditional LCD**

熊迪

Xiong Di

(Student ID: 81234593)

Supervisor: Professor Ogi Tetsuro

September 2014

Graduate School of System Design and Management,

Keio University

Major in System Design and Management

Summary of Master's Dissertation

Student Identification Number	81234593	Name	Xiong Di 熊迪
Title: Research on Layered 3D Display System based on the combination of Transparent LCD and Traditional LCD			
<p>Abstract:</p> <p>As computational power and the interest in 3D graphics have increased dramatically in recent years, 3D display technology has become an attractive field. Until now, there have been several kinds of 3D display devices. However, some factors like additional devices, complex structure and high cost have become the main reasons that why 3D display is still not being widely popularized. Considering the problems of current 3D display systems, we proposed and successfully built a new layered 3D display system by combining the transparent LCD and the traditional LCD.</p> <p>In this research, based on the special structure of our system, we put forward a combination of two methods (motion parallax and Depth-fused 3D) to realize 3D effect in our system. We made the experiments to prove the feasibility of the two methods in our system. And we also gave an application example of Ukiyoe to evaluate the 3D performance of our system.</p>			
<p>Keywords:</p> <p>3D, Transparent LCD, Traditional LCD, motion parallax, Depth-fused 3D, Depth perception</p>			

Table of contents

1	Introduction	9
1.1	Background	9
1.1.1	Summary of 3D display system	10
1.1.2	Problems of current 3D display system.....	15
1.2	Purpose	16
1.3	Structure of this thesis.....	16
2	Proposal	18
2.1	Concept of this research	18
2.2	Related research on layered 3D system	23
3	System building	26
3.1	Hardware design	26
3.2	Software design	29
4	Motion parallax (MP) experiment	34
4.1	Experimental purpose (MP)	34
4.2	Experimental principle (MP).....	34
4.3	Experimental procedure (MP).....	36
4.3.1	Preparation (MP).....	36
4.3.2	Execution (MP).....	38
4.4	Experimental result (MP).....	39
5	Depth-Fused 3D (DFD) experiment	48
5.1	Experimental purpose (DFD)	48
5.2	Experimental principle (DFD).....	48
5.3	Experimental procedure (DFD).....	50
5.3.1	Preparation (DFD).....	50

5.3.2	Execution (DFD).....	53
5.4	Experimental result (DFD).....	54
6	Motion parallax and Depth-fused 3D experiment.....	59
6.1	Experimental purpose (MP+DFD)	59
6.2	Experimental procedure (MP+DFD)	59
6.2.1	Preparation (MP+DFD).....	59
6.2.2	Execution (MP+DFD).....	61
6.3	Experimental result (MP+DFD)	61
7	Application example.....	64
8	Discussion	73
9	Conclusion	75
	Acknowledge	76
	Reference	77
	Conference attendance.....	79
	Appendix.....	80

List of figures

Fig.1-1: 3D Prospect on 3D Industry Applicable Fields.....	9
Fig.1-2: Principle of glasses type 3D display system.....	11
Fig.1-3: Principle of non-glasses type 3D display system.....	13
Fig.1-4: Principle of light source rotation type 3D display system.....	14
Fig.1-5: Principle of volumetric type 3D display system	14
Fig.1-6: Principle of holography type 3D display system	15
Fig.2-1: Image of Transparent LCD	18
Fig.2-2: Transparent LCD market forecast	19
Fig.2-3: Schematic diagram of layered 3D display system	20
Fig.2-4: Special structure of our layered 3D display system	21
Fig.2-5: Speculated effect of motion parallax in our layered 3D display system	21
Fig.2-6: Speculated effect of depth-fused 3D in our layered 3D display system	22
Fig.2-7: Speculated effect of motion parallax and depth-fused 3D in our system	23
Fig.2-8: Half-mirror type layered 3D display system.....	24
Fig.2-9: Projection type layered 3D display system.....	24
Fig.2-10: Immaterial DFD display using two fog screens	25
Fig.3-1: Real image of transparent LCD and traditional LCD.....	26
Fig.3-3: Front view of our system	27
Fig.3-2: Top view of our system.....	27
Fig.3-4: Side view of our system.....	28
Fig.3-5: Polarization phenomenon	28

Fig.3-6: Measurement board	29
Fig.3-7: Parameters to set glFrustum.....	31
Fig.4-1: Principle of motion parallax.....	35
Fig.4-2: Schematic of motion parallax experiment	36
Fig.4-3: Scene of motion parallax experiment	38
Fig.4-4: Variance of data for 0cm (1LCD).....	40
Fig.4-5: Variance of data for 4cm (2LCD).....	40
Fig.4-6: Variance of data for 8cm (2LCD).....	40
Fig.4-7: Variance of data for 12cm (2LCD).....	41
Fig.4-8: Contrast of setting depth and experimenters' perceived depth (0cm, 1LCD)	43
Fig.4-9: Contrast of setting depth and experimenters' perceived depth (4cm, 2LCD)	43
Fig.4-10: Contrast of setting depth and experimenters' perceived depth (8cm, 2LCD)	44
Fig.4-11: Contrast of setting depth and experimenters' perceived depth (12cm, 2LCD)	44
Fig.4-12: Contrast of the 4 situations in MP experiment.....	46
Fig.5-1: Principle of DFD	49
Fig.5-2: Schematic of DFD experiment.....	50
Fig.5-3: Final effect of color compensation	52
Fig.5-4: Scene of DFD experiment.....	53
Fig.5-5: Average result and variance of 10 people for the DFD experiment	54
Fig.5-6: Regression curve of the data for the DFD experiment	55
Fig.5-7: Result of the situation that the sum of luminance percentages is not	

100%.....	56
Fig.6-1: Schematic of MP+DFD experiment.....	60
Fig.6-2: Image of MP+DFD experiment.....	60
Fig.6-3: Average result of 10 people for the MP+DFD experiment.....	62
Fig.6-4: Variance of the data for the MP+DFD experiment.....	63
Fig.7-1: Separation of Ukiyoe.....	65
Fig.7-2: Schematic diagram of displaying 3D Ukiyoe in 2 LCDs.....	66
Fig.7-3: Schematic diagram of displaying 3D Ukiyoe in 1 LCD.....	67
Fig.7-4: Real pictures of Ukiyoe in two situations.....	68
Fig.7-5: Result of Q1.....	69
Fig.7-6: Result of Q2.....	70
Fig.7-7: Result of Q3.....	70
Fig.7-8: Result of Q4.....	71
Fig.8-1: An idea to realize free viewpoint for our system in the future.....	73
Fig.8-2: Image of an advanced layered 3D display system.....	74

List of tables

Table. 3-1: Speciafication contrast of transparent LCD and traditional LCD...	26
Table. 4-1: Parameters of the objects we prepared to display	37
Table. 4-2: Average results of 10 people for the MP experiment.....	39
Table. 4-3: ANOVA for the data of MP experiment	42
Table. 5-1: Combinations of luminance for DFD experiment	51
Table. 5-2: Color compensation table	52
Table. 5-3: ANOVA for the data of DFD experiment.....	55
Table. 5-4: ANOVA the situation (sum of luminance percentages is not 100%)	57

1 Introduction

1.1 Background

As computational power and the interest in 3D graphics have increased dramatically in recent years, 3D display technology has become an attractive field [Lee, 2009]. Compared with 2D display devices, 3D display devices are considered to be able to increase the sense of reality significantly. They are also being highly expected to improve the easiness and accuracy in the fields of remote control, design, medical care and so on.



Fig.1-1: 3D Prospect on 3D Industry Applicable Fields

Until now, there have been already several kinds of 3D display devices. For example, Glasses type (Anaglyph type, polarization type, time-division type...) : Observers will wear 3D glasses and then different images will be showed into their left eye and right eye, which will trigger 3D Perspective [Ohkoshi, 1980]. Non-glasses type (parallax barrier type, lenticular lens type...): instead of using glasses, the display surface will be covered by special structure which separates the light for left eye and right eye [Travis, 1997]. Depth-sampling and multiplexing type (light source rotation type, volumetric type...): integrating multiple layers with different depth by special mechanical structure. Holography: creating stereopsis of high quality by recording and releasing the light [Gabor, 1948].

However, some factors like additional devices, complex structure and high cost have become the main reasons that why 3D display is still not being widely popularized.

Besides the impact of surprising and newness, it is still fairly difficult to apply the 3D display into some industrial fields or even as a consumer product in normal life.

1.1.1 Summary of 3D display system

Here we make a brief summary of current main 3D display systems.

1.1.1.1 Glasses type

There are mainly 3 kinds of methods in glasses type. As figure1-2 shows that, they are

anaglyph type, polarization type and time-division type.

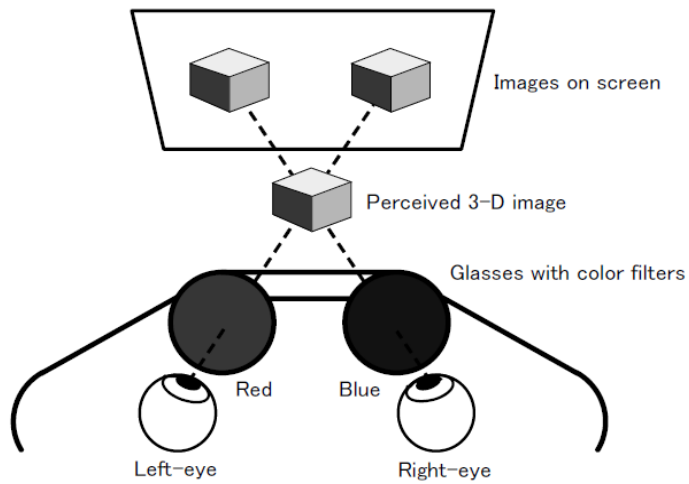

Anaglyph type

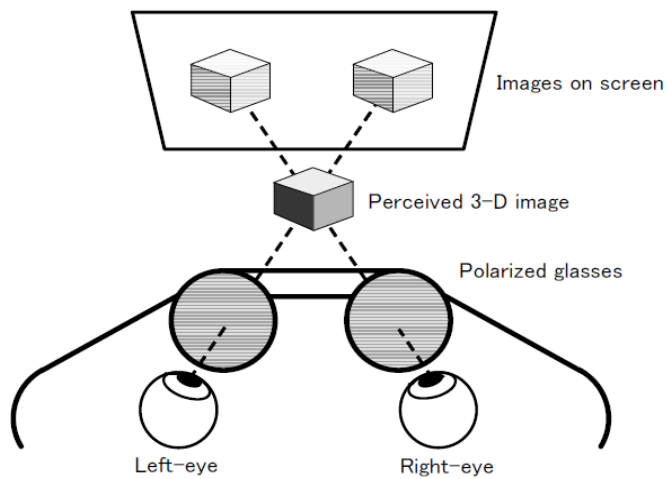

Polarization type

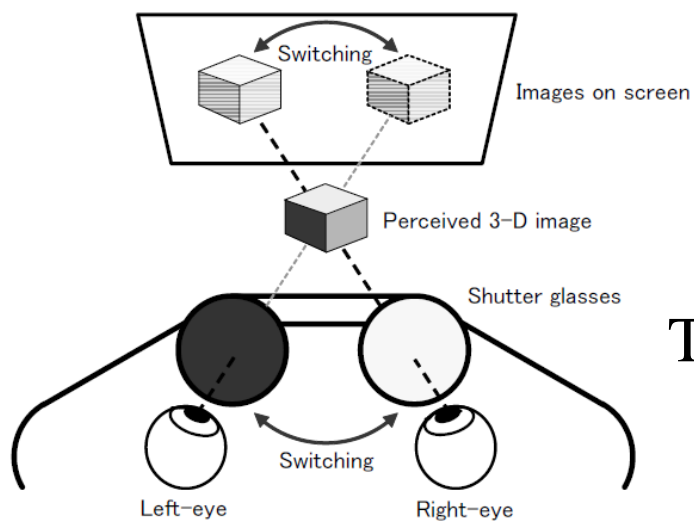

Time-division type

Fig.1-2: Principle of glasses type 3D display system

[Source: Takada, 2007]

Glasses type is the most popular 3D display system now. It uses one of the physiological characteristics of human beings called binocular disparity. Binocular disparity refers to the difference in image location of an object seen by the left and right eyes, resulting from the eyes' horizontal separation. The brain uses binocular disparity to extract depth information from the two-dimensional retinal images in stereopsis [Qian, 1997]. Observers will have to wear a pair of 3D glasses which can separate the original images by color, polarization, or time. Through the 3D glasses, different images into left and right eye will stimulate binocular disparity and then create stereopsis.

1.1.1.2 Non-glasses type

Besides glasses type there is also a technology called non-glasses type. There are mainly two kinds of this technology as figure1-3 shows, parallax barrier type and lenticular lens type. Non-glasses type also makes use of binocular disparity, but instead of separating images just before eyes, it separates images directly on the display screen. Different prepared images for left eye and right eye will pass through parallax barrier or lenticular lens and go into observer's left eye and right eye respectively. And then the different images will stimulate binocular disparity and create stereopsis.

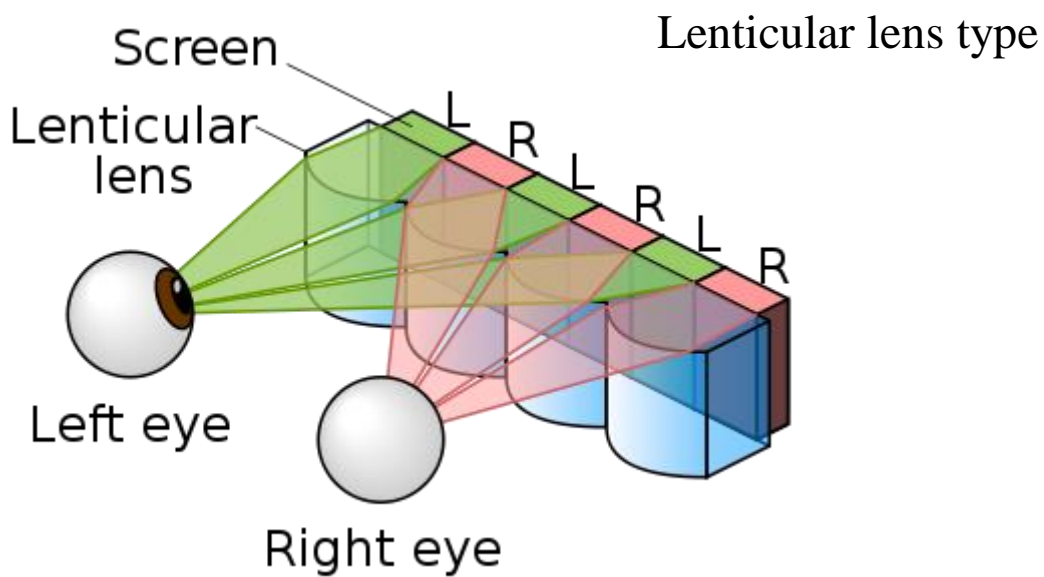
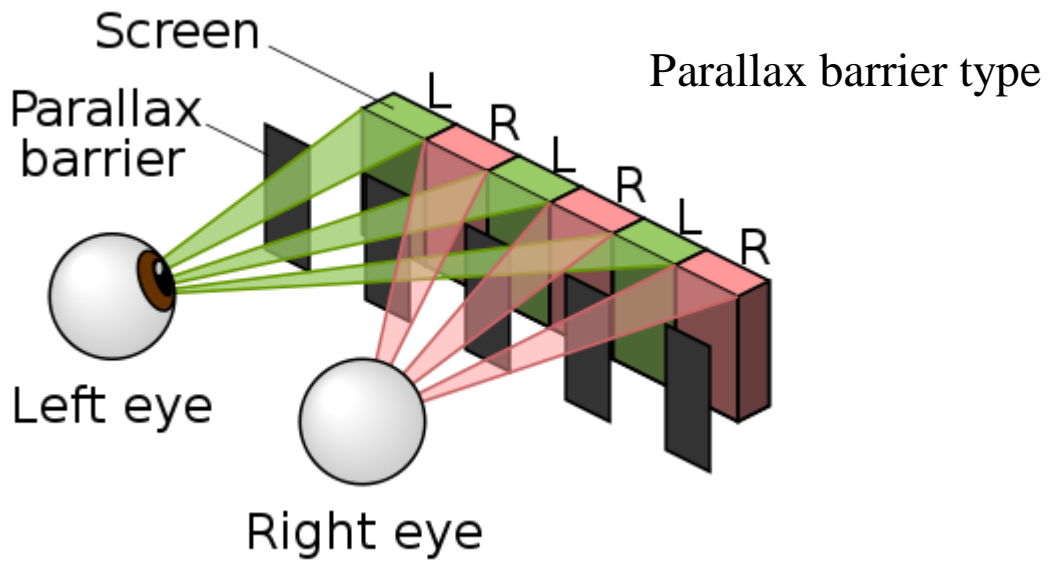

Fig.1-3: Principle of non-glasses type 3D display system

[Source:http://convert-to-3d.com/blog/3d_without_glasses_the_future_of_3d_technology.html]

Depth-sampling and multiplexing type integrates multiple layers with different depth by special mechanical structure to create 3D. Here we introduce two kinds of depth-sampling and multiplexing types. Figure1-4 shows the light source rotation type.

Rotating light source arrays will stimulates the retention of vision and then creates 3D.

Figure1-5 shows the volumetric type. Volumetric displays create 3D imagery via the emission, scattering, or relaying of illumination from well-defined regions in real space.

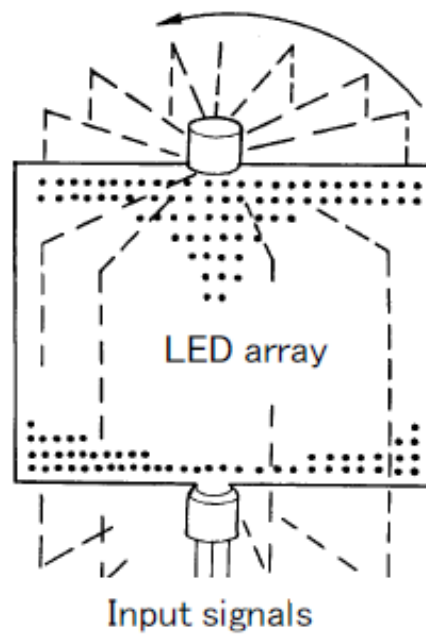

Fig.1-4: Principle of light source rotation type 3D display system

[Source: Takada, 2007]

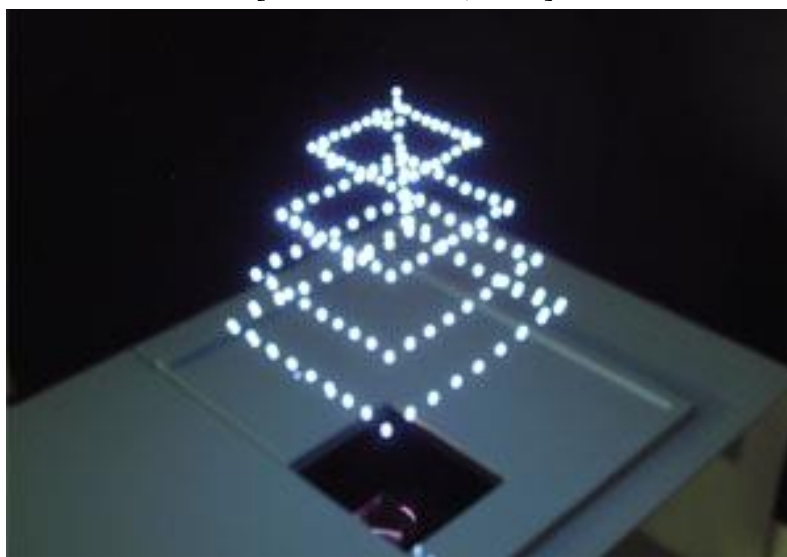

Fig.1-5: Principle of volumetric type 3D display system

[Source: http://www.aist.go.jp/aist_e/latest_research/2006/20060210/20060210.html]

1.1.1.3 Holography

Holography is said to be the ultimate method of 3D. It first records the interference patterns of incident light and reference light. And then play the interference patterns to create 3D. However, it seems like this technology still needs a long time to be applied.

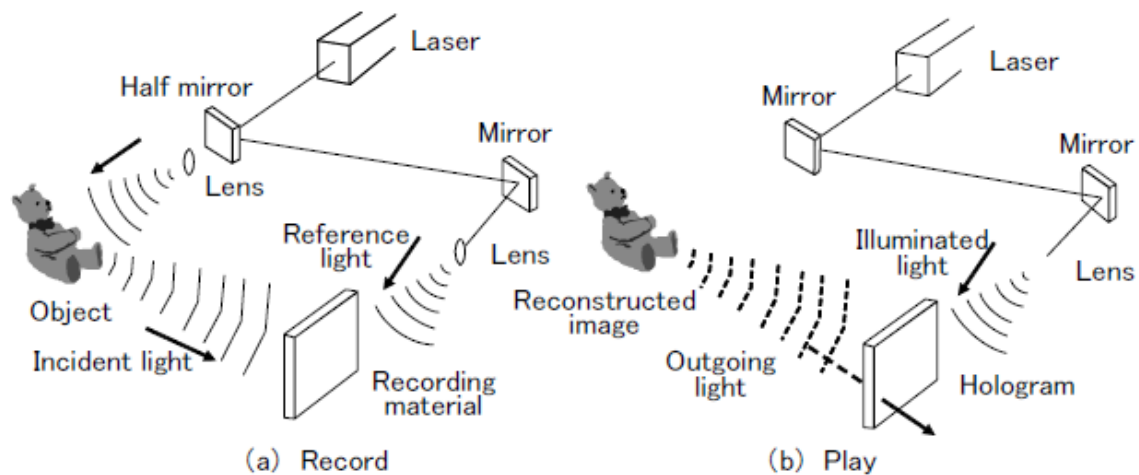

Fig.1-6: Principle of holography type 3D display system

[Takada, 2007]

1.1.2 Problems of current 3D display system

We already have a lot of 3D display systems until now, but why 3D display is still not being widely popularized? That is because they also have a lot of problems. For the glasses type, we need additional device – glasses, which will increase fatigue. For the non-glasses type, the available view point is very limited. For the depth-sampling and multiplexing type we need a complicated mechanical structure. For the holography,

we still have a lot of technical restrictions and cost problems.

1.2 Purpose

Considering the problems of current 3D display systems above, we are looking forward for a new 3D display system which can be easily used for a long time for anyone without additional devices. And also simple structure and reasonable cost are being expected. In this research we will try to realize these expectations by proposing a new layered 3D display system.

Furthermore, our ultimate goal is to change the current situation that 3D device isn't being popularized. We are looking forward to a future that our layered 3D display system can take the place of TV in every home and make all the people can easily enjoy the charm of 3D.

1.3 Structure of this thesis

In chapter one, we have given a general background of this research. We have identified the problems of current 3D display system. We also stated the general purpose of this research.

In chapter two, we will introduce the proposal of our layered 3D display system. We will introduce the concept of our research and the method to do it. Also we will make a brief comparison with existed layered 3D display systems.

In chapter three, we will talk about the system building. We will explain the design including both hardware and software.

In chapter four, we will conduct the first experiment, motion parallax experiment, to explore whether or in what way our system can change the ability to convey depth perception through this method.

In chapter five, we will do the second experiment, Depth-fused 3D experiment, to verify the phenomenon of DFD in our system and then explore how the depth perception will be changed by using DFD in a quantitative way.

In chapter six, we will integrate motion parallax and Depth-fused 3D and explore how these two methods can make contributions to the 3D performance of our system together.

In chapter seven, we will give out an example by using the two methods we have verified in the above chapters. We will use the famous Japanese painting “Ukiyoe” as our content and collect the feedback from experimenters.

In chapter eight, we will make discussion about the insufficient part of this research and the future issues.

Lastly in chapter nine, we will recap the results of this research once again and make a conclusion of this research.

2 Proposal

2.1 Concept of this research

We got an inspiration for 3D display research from a brand-new technology which is called transparent LCD. Transparent LCD is a new type LCD which you can not only use it as the traditional LCD but also you can see through it. Figure2-1 shows an example of transparent LCD. Samsung, the giant in the electronic field claimed that they had begun the mass production of transparent LCD in 2012. It makes the cost of transparent LCD be decreasing. Based on the decreasing cost and exclusive transparent function, Display Bank, a display researching organization, has published a market forecast of transparent LCD which shows it will be highly probable for the transparent LCD to bring a huge market in recent years.



Fig.2-1: Image of Transparent LCD

[Source: <http://fringeskill.blogspot.jp/2011/11/samsung-transparent-lcd-panels-we-see.html>]

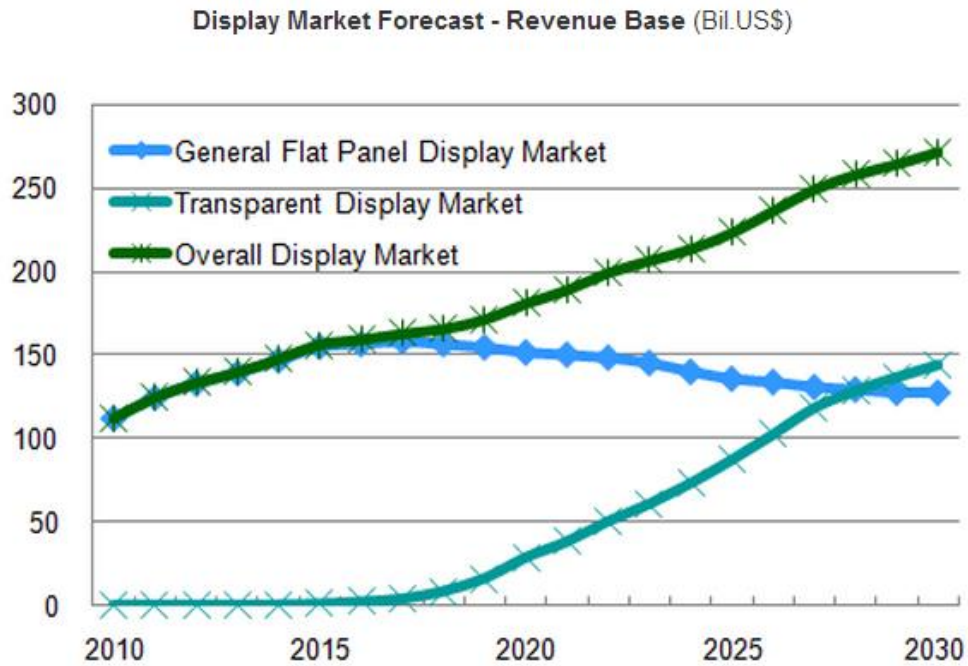

Fig.2-2: Transparent LCD market forecast

[Source: Display Bank, 2011]

By using the special function of this notable product, we came up with a new idea to build a layered 3D display system as figure2-3. We try to combine the transparent LCD and traditional LCD. Because the front layer is transparent, it makes us able to combine the images of front and rear and use the space which is not limited in the two layers. We want to know whether it is possible to create comparatively better stereoscopic effect by fusing the images of the two LCDs than the situation that we just create 3D graphs on one traditional LCD. If compared with the current 3D display systems, firstly this system does not need any additional equipment like glasses and owns a compact structure; secondly this is at a reasonable cost (our budget for this system is around 120,000 yen, on the other hand the average price for 3D TV is

around 200,000 yen); and theoretically there supposes to be less fatigue because the display system requires less convergence accommodation. So if our hypothesis is proved and this system is successfully verified and validated, it may be a new approach to create a new 3D display system which is being expected.

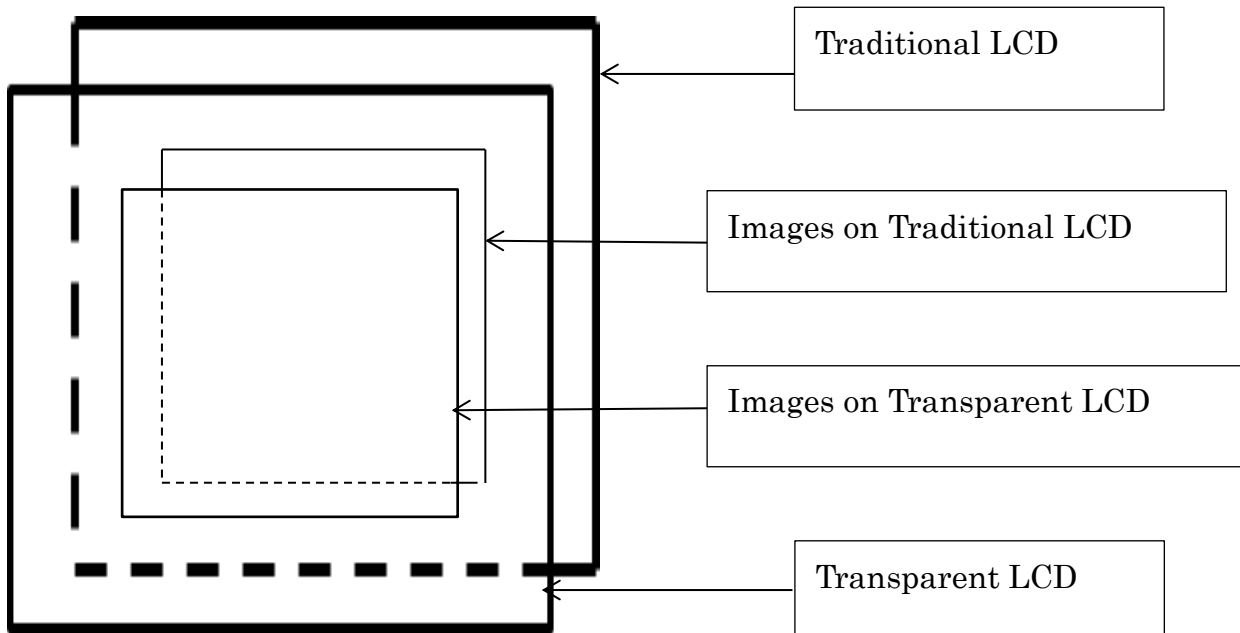

Fig.2-3: Schematic diagram of layered 3D display system

Moreover, how to create 3D sensation by our system will be the most significant thing that we want to know. Here we will introduce our idea about how to create 3D effect by our system.

The most special feature of this system is that we separate the space into 3 parts by the two LCDs as figure2-4 shows. How to make full use of the part 1, part 2 and part 3 is a critical issue. Starting from the special structure of our system, we came up with an idea.

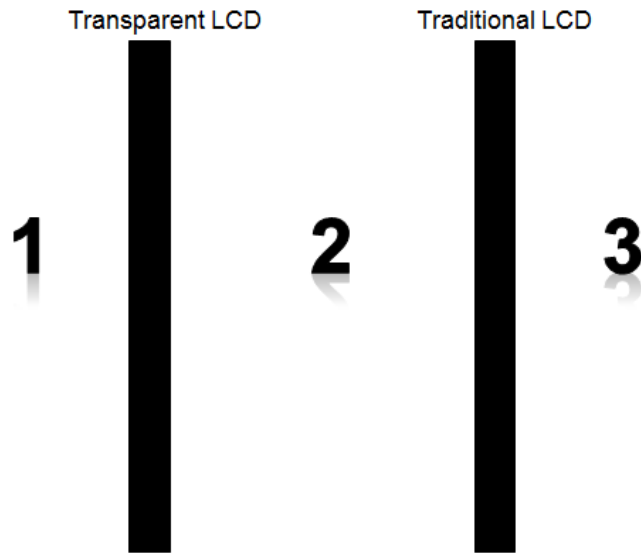

Fig.2-4: Special structure of our layered 3D display system

Actually even for one traditional LCD, if we adopt some special methods to create the graphics, to some extent it will also be able to achieve 3D effect. One of the special methods is called motion parallax which is one kind of visual illusions of human beings (we will discuss in detail in Chapter 4). Based on this fact, we speculate that if we adopt motion parallax in our system, each of the two LCD will have a certain range round themselves to be able to show 3D effect as figure2-5 shows.

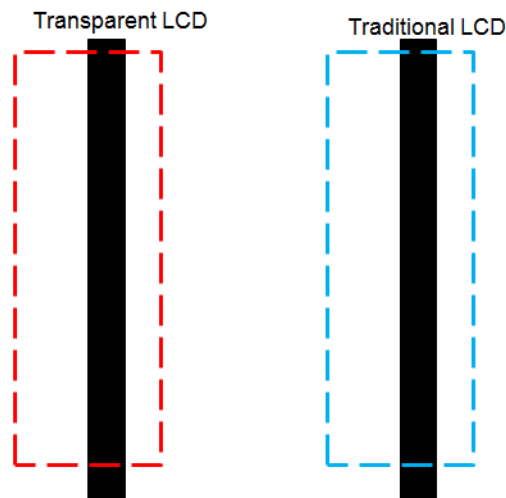

Fig.2-5: Speculated effect of motion parallax in our layered 3D display system

However, we can find that the middle part between the transparent LCD and the traditional LCD is not being used. So we have to think about another method to make use full use of this space. We came up with an interesting unencumbering pseudo-3D display technique which is called depth-fused 3D (DFD) by [Suyama, 2004]. DFD means that images at intermediate depth can be produced by simply controlling the luminance of two stacked 2D images [Date, 2007] (We will discuss in detail in Chapter 5). By using DFD, we speculate that we can fill up the space between the 2 LCDs with 3D effect as figure2-6 shows.

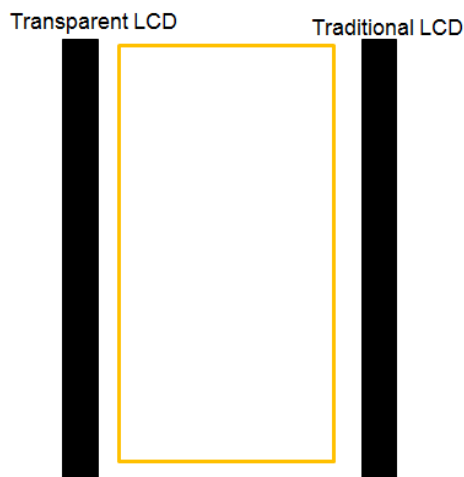

Fig.2-6: Speculated effect of depth-fused 3D in our layered 3D display system

Then, if we combine motion parallax and DFD, we further speculate that the range where we can feel 3D will be like it shows in figure2-7. Compared with one traditional LCD the range is supposed to be much wider.

In this research, we will start from the hypotheses above and try to prove them by experiments. If all the hypotheses above are proved, it will turn out that we have

found the valid way to create 3D by using our system. And it will also prove that our layered 3D display system can have a better capability to create 3D effect than one traditional LCD.

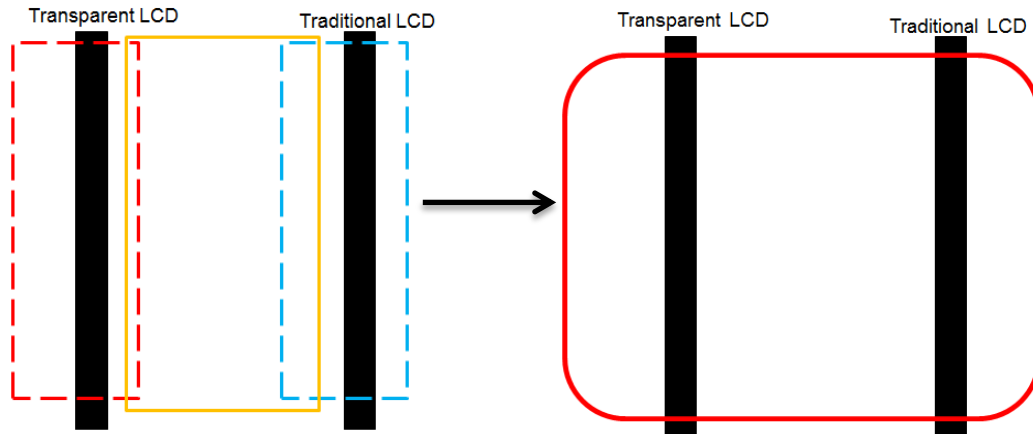

Fig.2-7: Speculated effect of motion parallax and depth-fused 3D in our system

2.2 Related research on layered 3D system

Until now, there have been several researches on the layer 3D display system. Most of them used DFD (Depth-fused 3D).

One of these researches is called half-mirror type. It was achieved by superimposing two 2D display screens using half mirrors. The luminance of overlapping images was the accurate addition of the luminance of two screens, so the perceived depth was proportional to the luminance ratio of the two screens. The only additional optical component was a half mirror, so high-quality 3D images could be obtained easily.

However, the image appeared to be located at a depth farther away than the half

mirror, and the size of the apparatus was large. [Date, 2007]

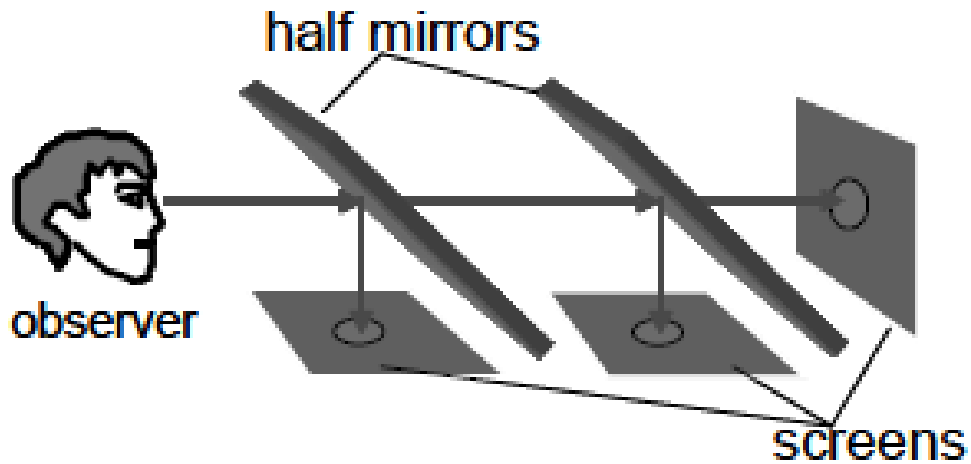

Fig.2-8: Half-mirror type layered 3D display system

[Source: Date, 2007]

Another type is called projection type. One research of this type was achieved by using a stack of two transparent screens with front and rear projectors, as shown in figure2-9 that stack can be used to reduce the thickness of the display apparatus and the distance of the image from the observer to smaller values than those of the half-mirror type [Date, 2007].

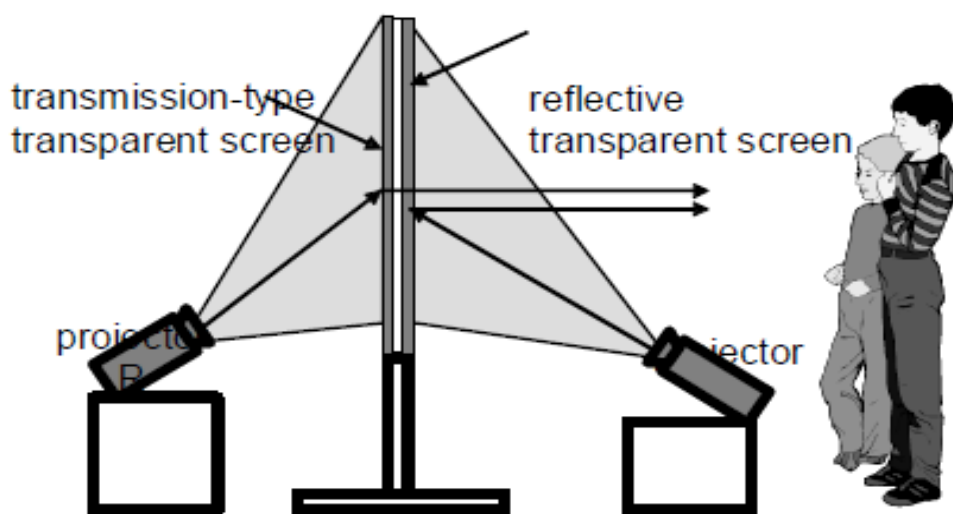

Fig.2-9: Projection type layered 3D display system

[Source: Date, 2007]

Another similar research used fog screen instead of the two transparent screens, as shown in figure2-10. However, two projectors are indispensable for this type, the size of the apparatus is still large.



Fig.2-10: Immaterial DFD display using two fog screens

[Source: Lee, 2009]

3 System building

3.1 Hardware design

We chose the 22 inches transparent LCD (Samsung) and the traditional LCD (HP 2209t). Table3-1 is a simple contrast of their specifications.

Table. 3-1: Specification contrast of transparent LCD and traditional LCD

Specification	Transparent LCD (Samsung)	Traditional LCD (HP 2209t)
Module Size	22 inches	21.5 inches
Weight	1.3kg	6.4kg
Pixel Pitch	0.282mm	0.250mm
Display Colors	16.7M	1677M
Numbers of Pixels	1680*1050	1920*1080



Fig.3-1: Real image of transparent LCD and traditional LCD

We built a frame to fix these two LCDs and also added some lighting equipment. The transparent LCD is in the front and the traditional one is at the back. Figure 3-3, figure 3-4 and figure 3-5 show the front view, top view and side view of this system.

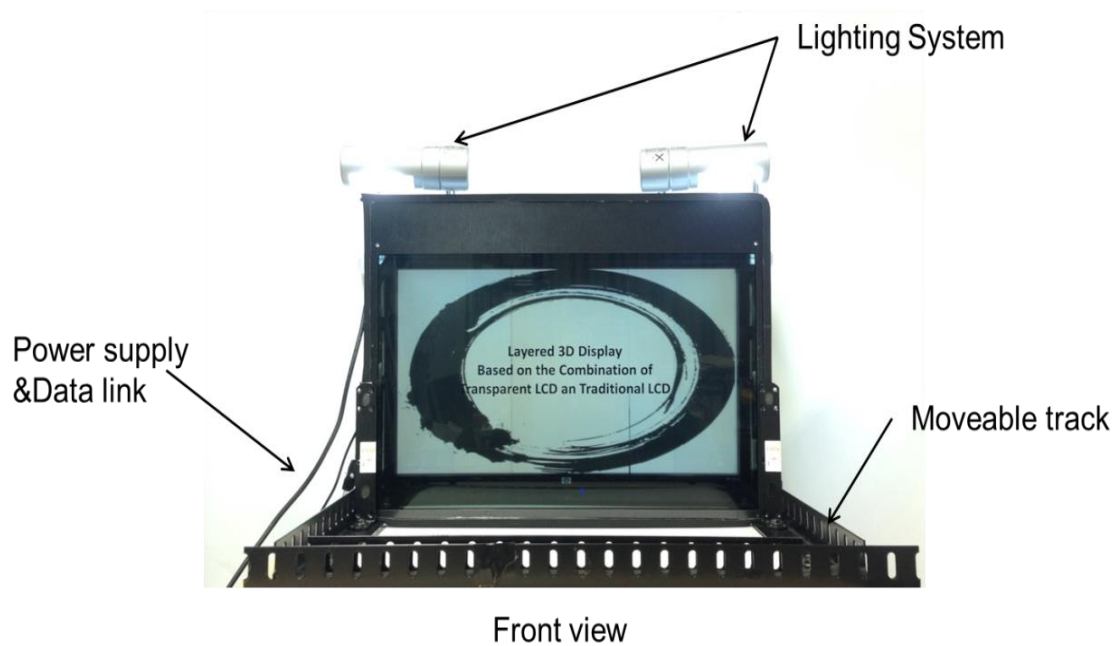

Fig.3-3: Front view of our system

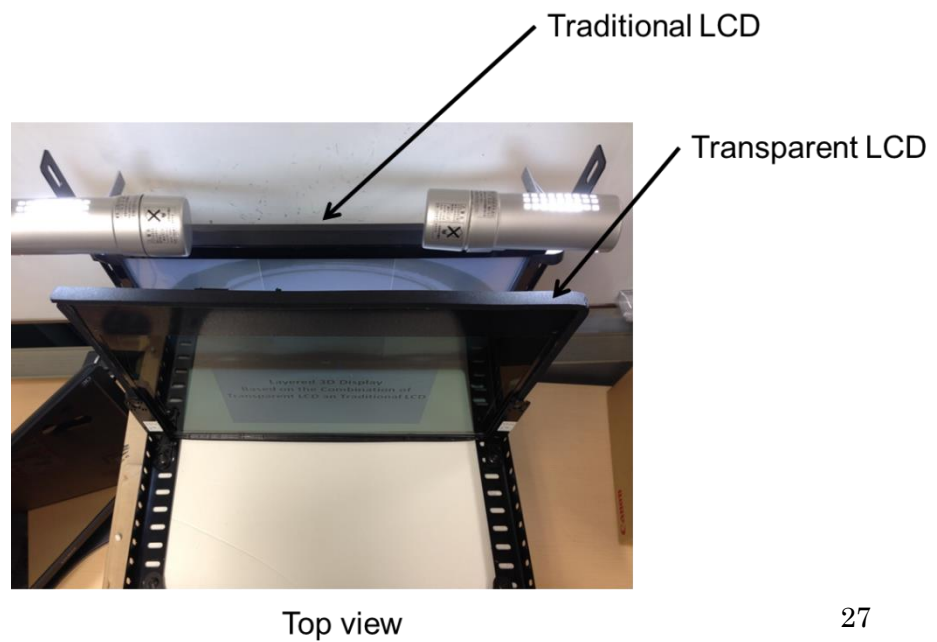

Fig.3-2: Top view of our system



Side view

Fig.3-4: Side view of our system

Because of the polarization, actually we cannot see the back LCD through the front transparent LCD. So in order to solve this problem, we added a kind of plastic material to break the polarization and make it possible to see through the front LCD to the back LCD. Figure3-5 shows the polarization phenomenon.

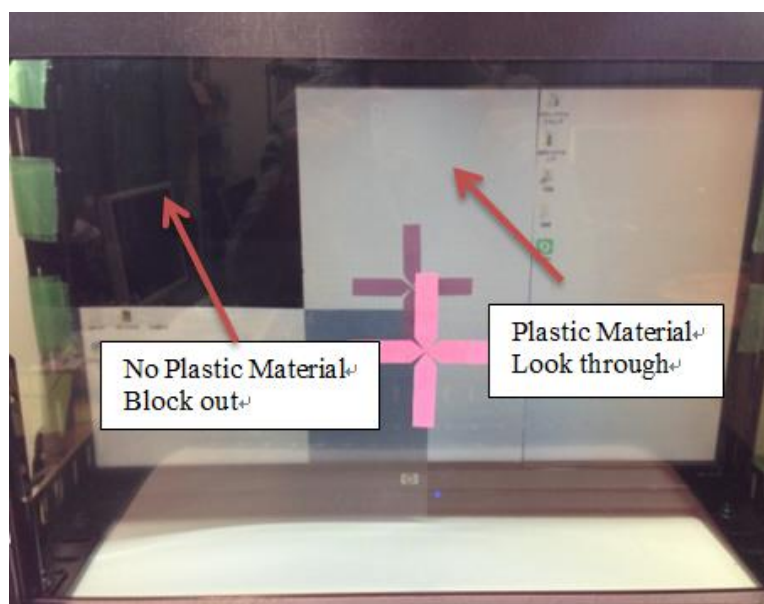

Fig.3-5: Polarization phenomenon

In addition, in order to measure perceived depth in the following experiments. We also made a measurement board as figure3-6 shows. The measurement card can be smoothly moved to front or back in the track that we set on the board.



Fig.3-6: Measurement board

3.2 Software design

In order to explore 3D effect in our system, we need to set up a software environment which allows us to create 3D graphics. We chose the OpenGL (Open Graphics Library) which is a cross-language, multi-platform application programming interface (API) for rendering 2D and 3D vector graphics. [Segal, 2010] However, because we have two LCDs in this system, besides the programming platform, there are some other

problems that we have to consider.

We have to make sure that from the front view no matter the situation we only watch at one traditional LCD or the situation we watch through the transparent LCD to the traditional LCD in our system, the pattern, the size, the location and the movement of the images should be completely the same.

To make sure this, the first problem we have to solve is the desynchronization. When we display on two LCDs, we actually input the signals by two channels. If we use two different PCs to offer the input signals, because of the different specifications the desynchronization seems to be hardly avoided. We made it possible to output two viewports from one application using one PC, which eliminated the problem of desynchronization.

Another significant problem is that we have to keep the location and size unchanged (when seen from the front). By using the function called `glFrustum()` in OpenGL, which produces a perspective projection, we made it possible to draw objects which are with the real world coordinates in our system. Simply speaking, by using `glFrustum()`, we can simulate the movement of an object of real size and at real location. The size we see on the LCD will be totally the same as the objects in real world coordinates.

To set the function of `glFrustum` (`fleft`, `fright`, `fbottom`, `ftop`, `zNear`, `zFar`), we need to

know several parameters. Figure3-7 shows the parameters that we have to set.

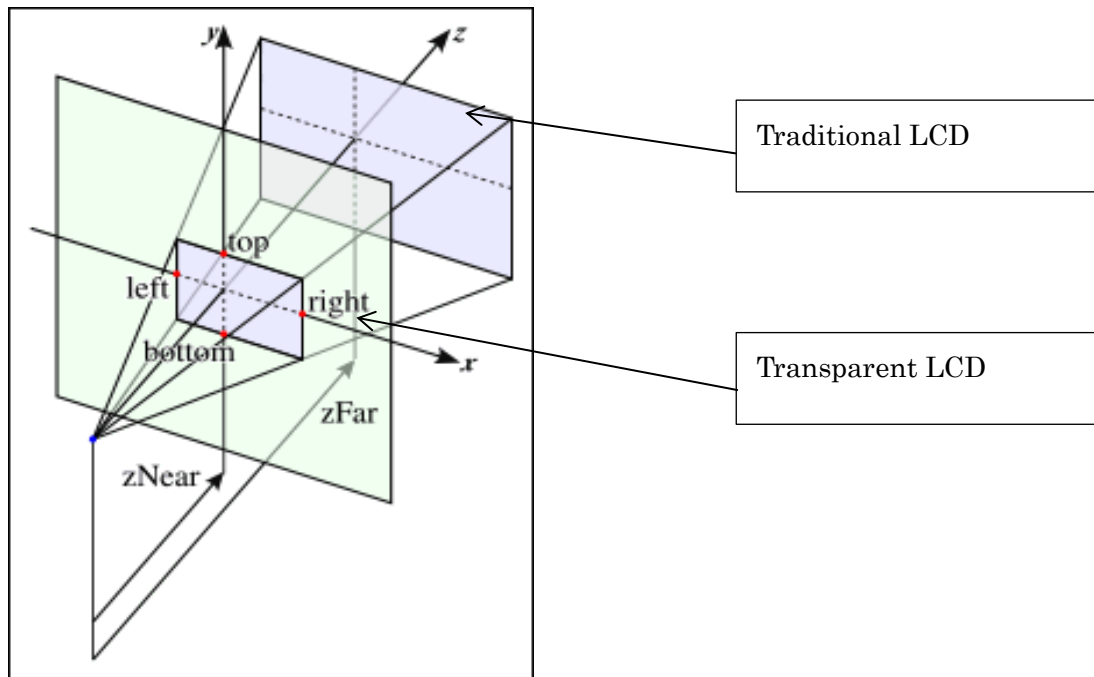

Fig.3-7: Parameters to set glFrustum

However, we cannot directly measure these parameters. We have to calculate them through some equations as follows.

$$zNear = eye_z - near_z; \quad (3-1)$$

$$zFar = eye_z - far_z; \quad (3-2)$$

$$fleft = -(disp_width / 2.0f + eye_x - disp_x) * zNear / eye_z - disp_z; \quad (3-3)$$

$$fright = (disp_width / 2.0f - eye_x - disp_x) * zNear / eye_z - disp_z; \quad (3-4)$$

$$fbottom = -(disp_height / 2.0f + eye_y - disp_y) * zNear / eye_z - disp_z; \quad (3-5)$$

$$ftop = (disp_height / 2.0f - eye_y - disp_y) * zNear / eye_z - disp_z; \quad (3-6)$$

Here are the explanations of the parameters which we can directly measure:

```
// eye position: (eye_x, eye_y, eye_z)
```



```

// center of the display: (disp_x, disp_y, disp_z)

// real size of the display(viewport): disp_width, disp_height

// z value of transparent LCD: near_z

// z value of traditional LCD: far_z

```

What we have to do to set the function `glFrustum()` is just to measure the parameters above and fill the configuration table below. Here we give an example of our configuration table.

```

// =====
// configuration
// -----

#define WINDOW_WIDTH 3350
#define WINDOW_HEIGHT 1010

// eye position in global coordinate system (cm)

#define EYE_X 0.0f
#define EYE_Y 0.0f
#define EYE_Z 212.0f

// -----
// display 1: normal LCD
// -----

#define VIEWPORT1_X_PIXEL 0
#define VIEWPORT1_Y_PIXEL 0
#define VIEWPORT1_WIDTH_PIXEL 1665
#define VIEWPORT1_HEIGHT_PIXEL 1100

// real size of display1 (cm)

```

```

#define DISPLAY1_WIDTH 47.0f
#define DISPLAY1_HEIGHT 26.2f

// display1 center position in global coordinate system (cm)

#define DISPLAY1_X 0.0f
#define DISPLAY1_Y 0.0f
#define DISPLAY1_Z 0.0f

#define DISPLAY1_NEAR_Z (DISPLAY1_Z + DEFAULT_FRUSTUM_NEAR_Z)
#define DISPLAY1_FAR_Z  (DISPLAY1_Z + DEFAULT_FRUSTUM_FAR_Z)

// -----
// display 2: transparent LCD
// -----
#define VIEWPORT2_X_PIXEL 1675
#define VIEWPORT2_Y_PIXEL 0
#define VIEWPORT2_WIDTH_PIXEL 1675
#define VIEWPORT2_HEIGHT_PIXEL 1100

// real size of display2 (cm)

#define DISPLAY2_WIDTH 47.2f
#define DISPLAY2_HEIGHT 29.5f

// display2 center position in global coordinate system (cm)

#define DISPLAY2_X 0.0f
#define DISPLAY2_Y -0.4f
#define DISPLAY2_Z 6.0f

#define DISPLAY2_NEAR_Z (DISPLAY2_Z + DEFAULT_FRUSTUM_NEAR_Z)
#define DISPLAY2_FAR_Z  (DISPLAY2_Z + DEFAULT_FRUSTUM_FAR_Z)

```

Until now, we have successfully set up a software environment which allows us to create 3D graphics in our system.

4 Motion parallax (MP) experiment

4.1 Experimental purpose (MP)

By using motion parallax which is one of the methods to create 3D sensation, we try to measure and compare the depth perceptions in the situation of one LCD and the situation of two LCDs to explore that comparing with one traditional LCD, whether or in what way our system can change the ability to convey depth perception. In addition to that, we also want to explore that which is the best interval for the transparent LCD and traditional LCD.

4.2 Experimental principle (MP)

Motion Parallax means as the viewpoint moves side to side, the objects in the distance appear to move slower than the objects close to our eyes [Yokozawa, 2010]. Because of the relativity, inversely if our viewpoint keeps static and we make the objects which have different distances from our eyes move at the same speed, we can still feel the objects in the distance appear to move slower than the objects close to our eyes.

As a result, by using the principle of motion parallax, actually even one simple traditional LCD can also convey a certain depth perception. For example, in Figure 4-1 we simulate the motion parallax. Figure4-1 (a) shows the side view. We draw several rows of objects with different Z coordinates and give them the same moving

speed to the same direction (By using OpenGL, we can simulate the movement of objects which has different distances from our eyes even on the flat LCD). Figure4-1 (b) shows the front view. At this moment, what our brain feels is actually that the objects which are near to us (smaller Z coordinate) moves faster than the ones which are far from us (bigger Z coordinate). Then our brain will have a depth perception of the objects. We may have an optical illusion that some of the objects are flying out from the flat LCD and some are at the back of the LCD. This is why even a flat LCD can also convey depth perception to a certain extent.

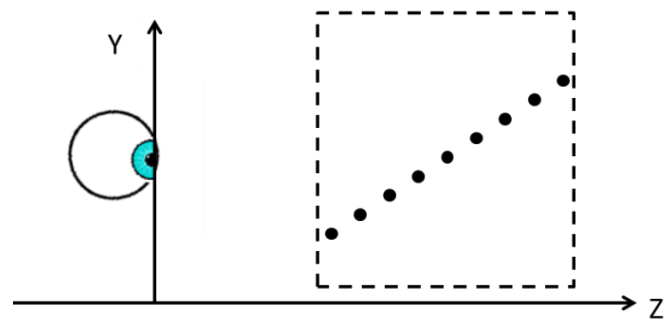

(a)

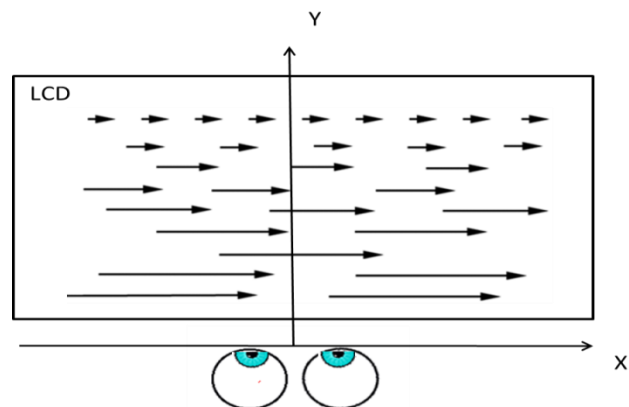

(b)

Fig.4-1: Principle of motion parallax

So, what about our system? Compared with one traditional LCD, can our system have better performance? We will introduce the details of experiment in the following section.

4.3 Experimental procedure (MP)

4.3.1 Preparation (MP)

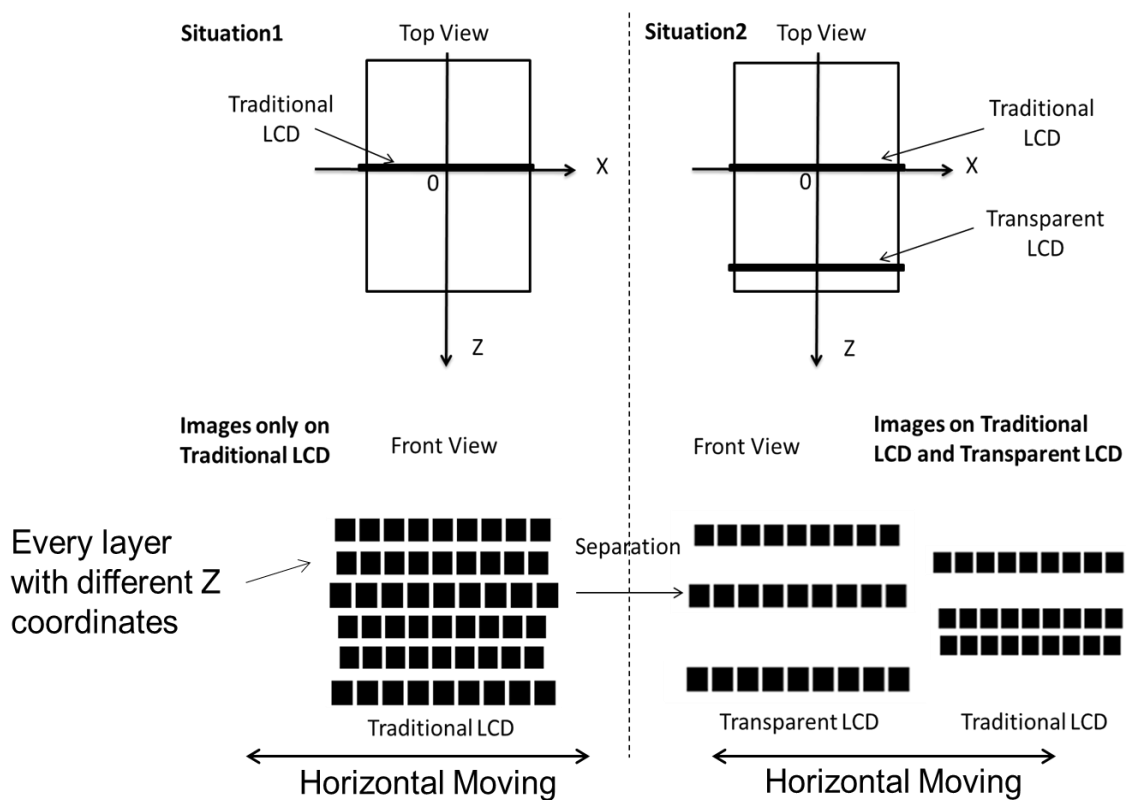

Fig.4-2: Schematic of motion parallax experiment

Figure4-2 shows the schematic of our experiment. In situation 1 we display some black rectangles only on the rear traditional LCD. Each line of these rectangles has different Z coordinate. In the situation 2, we separate the original rectangles into two groups. We display one group with smaller z coordinates (back 3 layers) on the

traditional LCD and another group with bigger coordinates (front 3 layers) on the transparent LCD. For both situation 1 and situation 2, we make all the rectangles do the horizontal moving at the same speed.

Because we also want to explore that which is the best interval for the transparent LCD and traditional LCD, in situation 2 we tried 3 different intervals of the two LCDs. They are 4cm, 8cm and 12cm. So totally we tested 4 kinds of intervals, 0cm (one traditional LCD), 4cm, 8cm and 12cm. In order to decrease the absolute errors, we prepared 3 patterns of images for each situation. That is to say every experimenter totally has to observe for 12 times. Most parameters of the patterns are the same except for the sequence that the objects are randomly arranged in the Y axis. The same parameters are as follows.

Table. 4-1: Parameters of the objects we prepared to display

Size of Rectangles	X Interval	Y Interval	Z Interval	Number of Rows	Moving Speed	Moving distance
2.5cm*2.5cm	3cm	3.5cm	4cm	6	0.8 cm/sec	13.5cm

4.3.2 Execution (MP)

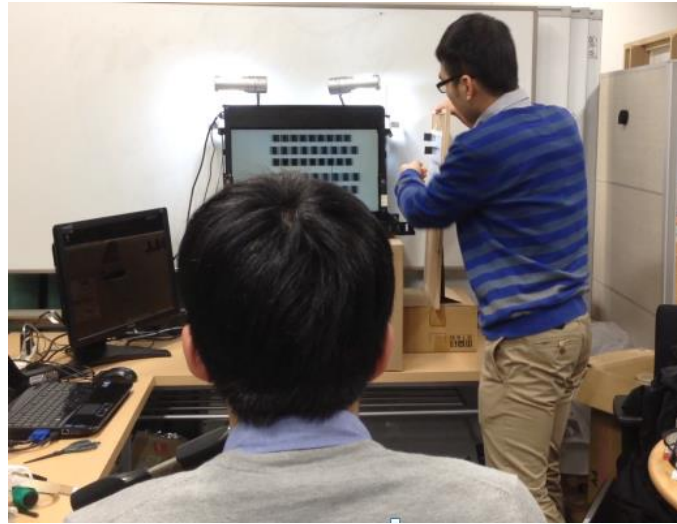

Fig.4-3: Scene of motion parallax experiment

Figure4-3 shows the scene of motion parallax experiment. The experimenter sat on the chair in a certain position and put his jaw on the edge of the top part of a tripod which is also fixed in a certain position (2m from the front LCD). Ask him to watch at our system. Then show him the card we prepared and tell him there will be a lot of rectangles which has the same size of this card moving in our system.

Alternately we changed the intervals of two LCDs with the movable track, display the whole images just on the traditional LCD and then separated images on both traditional LCD and transparent LCD correspondently. At the same time, we used the measurement board that we mentioned in section 3.1 to measure experimenters' depth perception. The measurement card can be smoothly moved to front or back in the track that we set on the board. We moved the card in the first row to different

positions in the Z direction. Ask the experimenter at which point he can feel the card is at the same depth with the first row of our rectangles. When the position was decided we retain our card in that position. Then pick up another card and move to the next row below. Finally we recorded the positions of 6 cards.

4.4 Experimental result (MP)

Totally we had 10 people do the experiment. And in every situation, for each person we tested 3 patterns of images (changing the sequence in the depth direction).

Table. 4-2: Average results of 10 people for the MP experiment

cm	Transparent LCD			Traditional LCD		
	Layer1	Layer2	Layer3	Layer4	Layer5	Layer6
Setting	10.00	6.00	2.00	-2.00	-6.00	-10.00
0cm (1LCD)	0.60	-0.06	-1.04	-1.87	-2.08	-2.69
4cm(2LCD)	3.38	2.85	1.76	-2.65	-3.12	-3.38
8cm(2LCD)	6.33	5.46	4.77	-2.49	-3.15	-3.60
12cm(2LCD)	10.59	10.08	9.37	-1.94	-2.78	-3.34

Table4-2 shows the average results of the 10 people. In this table, the row of Setting means the depth of the objects we set in the program. The row of 0cm (1LCD) means the perceived depth of the objects in the situation of only one traditional LCD. The row of 4cm (2LCDs) means the perceived depth of the objects in the situation of two LCDs with an interval of 4cm. The row of 8cm(2LCDs) means the perceived depth of the objects in the situation of two LCDs with an interval of 8cm. The row of 12cm (2LCDs) means the perceived depth of the objects in the situation of two LCDs with

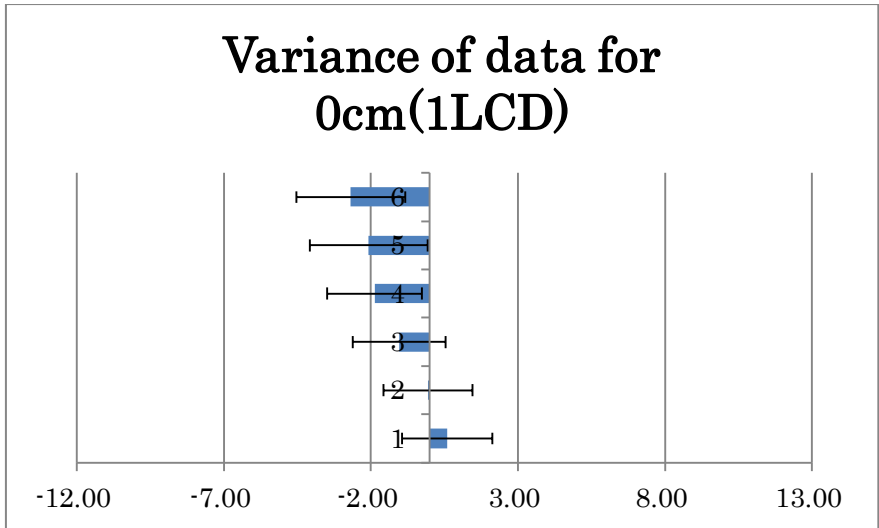

Fig.4-4: Variance of data for 0cm (1LCD)

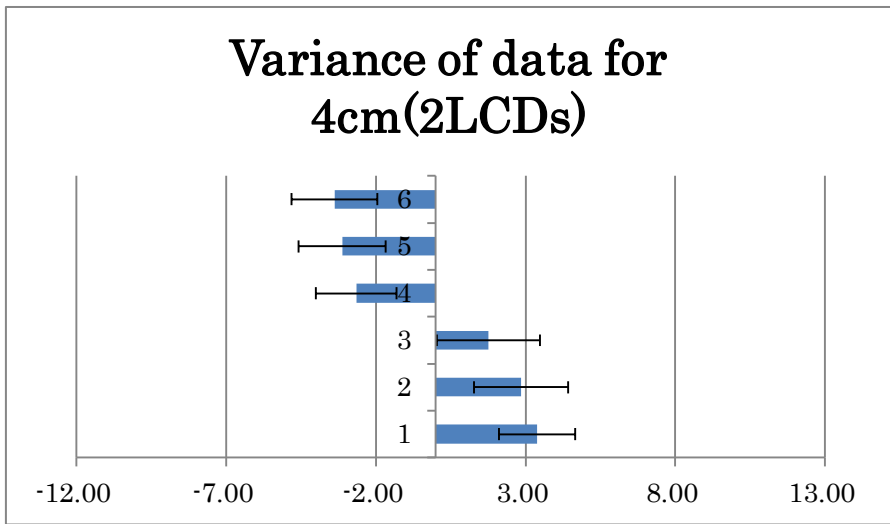

Fig.4-5: Variance of data for 4cm (2LCD)

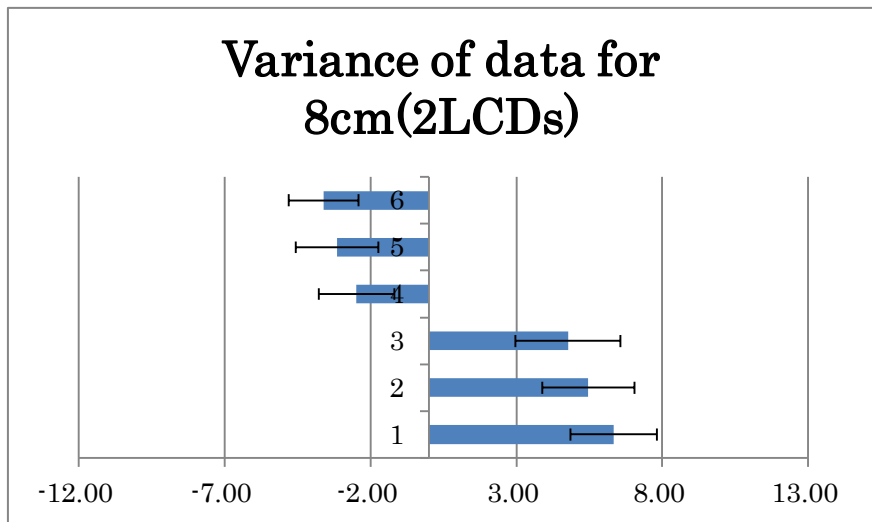

Fig.4-6: Variance of data for 8cm (2LCD)

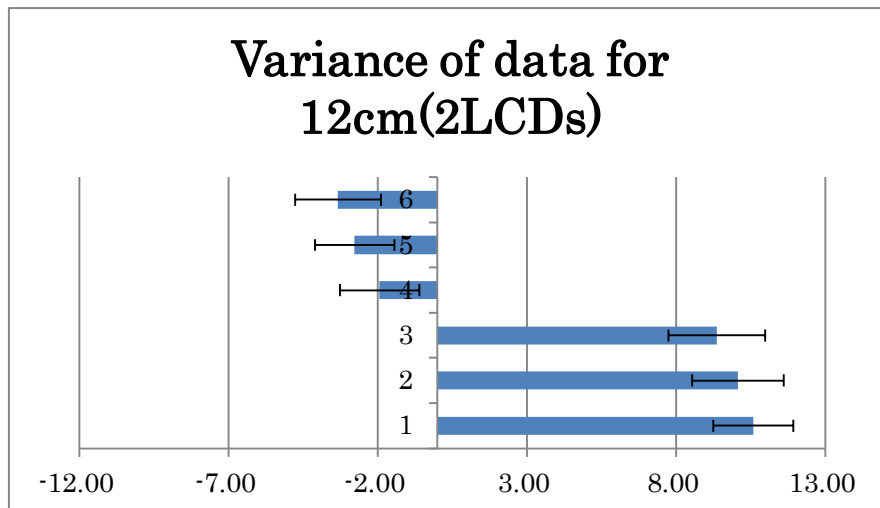

Fig.4-7: Variance of data for 12cm (2LCD)

an interval of 12cm. Figure4-4, 4-5, 4-6 and 4-7 show the variance for each situation.

Since this experiment is based on the perception of different people, we can find from figure4-4, 4-5, 4-6 and 4-7 that the variance is not so stable. As a result, before we start the further analysis of these data, we should first make sure the significance level of our data. We held analysis of variance (ANOVA) test for everyone's data and got the result which is showed in table4-3. In table4-3 , it shows that for every experimenter, the significance level (Sig) is under 0.05. It is indicated that there is statistical significance in the 4 groups of data for 0cm (1LCD) , 4cm (2LCDs) , 8cm (2LCDs) , 12cm (2LCDs) , which proves that in our system different interval has different influence on the experimenters' perceived depth.

Table. 4-3: ANOVA for the data of MP experiment

Experimenter No.	Source	Type III Sum of Squares	df	Mean Square	F	Sig.
1	LayerDepth * Interval	303.004	15	20.200	15.874	.000
2	LayerDepth * Interval	341.339	15	22.756	13.845	.000
3	LayerDepth * Interval	376.992	15	25.133	66.187	.000
4	LayerDepth * Interval	215.933	15	14.396	15.985	.000
5	LayerDepth * Interval	401.043	15	26.736	34.504	.000
6	LayerDepth * Interval	308.634	15	20.576	27.048	.000
7	LayerDepth * Interval	287.193	15	19.146	15.134	.000
8	LayerDepth * Interval	166.432	15	11.095	11.032	.000
9	LayerDepth * Interval	208.943	15	13.930	16.632	.000
10	LayerDepth * Interval	267.752	15	17.850	13.879	.000

After finishing the initial analysis for the statistical significance of our data, here we will explore how these data are connected to the capability of our system to create 3D effect. To have a further analysis for the data, we made several figures which show the contrast of setting depth and experimenters' perceived depth in more intuitional way.

Here is the explanation of the parameters in figure4-8, 4-9, 4-10 and 4-11.

Middle barrier: the position of traditional LCD, which is also the Z coordinate of 0.

Target : the target depth we set in the program.

1LCD: average perceived depth in the situation of one traditional LCD.

2LCD 4cm: average perceived depth for 2 LCDs with an interval of 4cm.

2LCD 8cm: average perceived depth for 2 LCDs with an interval of 8cm.

2LCD 12cm: average perceived depth for 2 LCDs with an interval of 12cm.

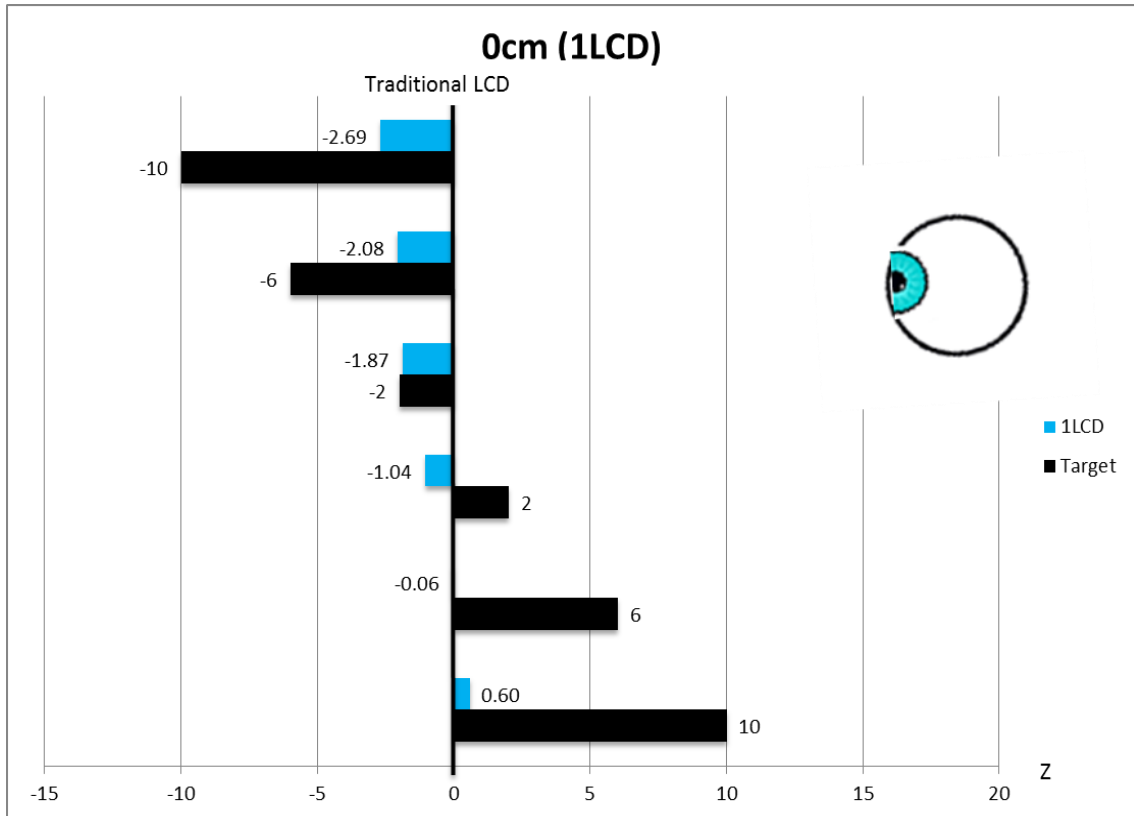

Fig.4-8: Contrast of setting depth and experimenters' perceived depth (0cm, 1LCD)

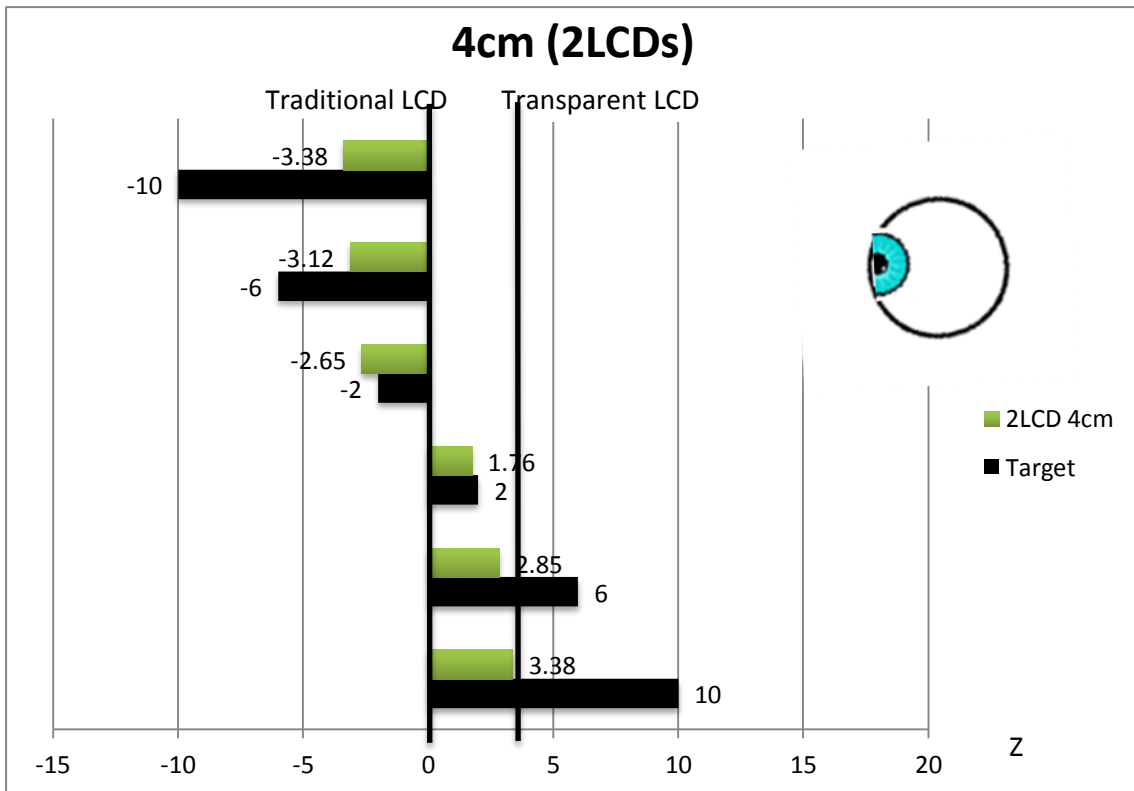

Fig.4-9: Contrast of setting depth and experimenters' perceived depth (4cm, 2LCD)

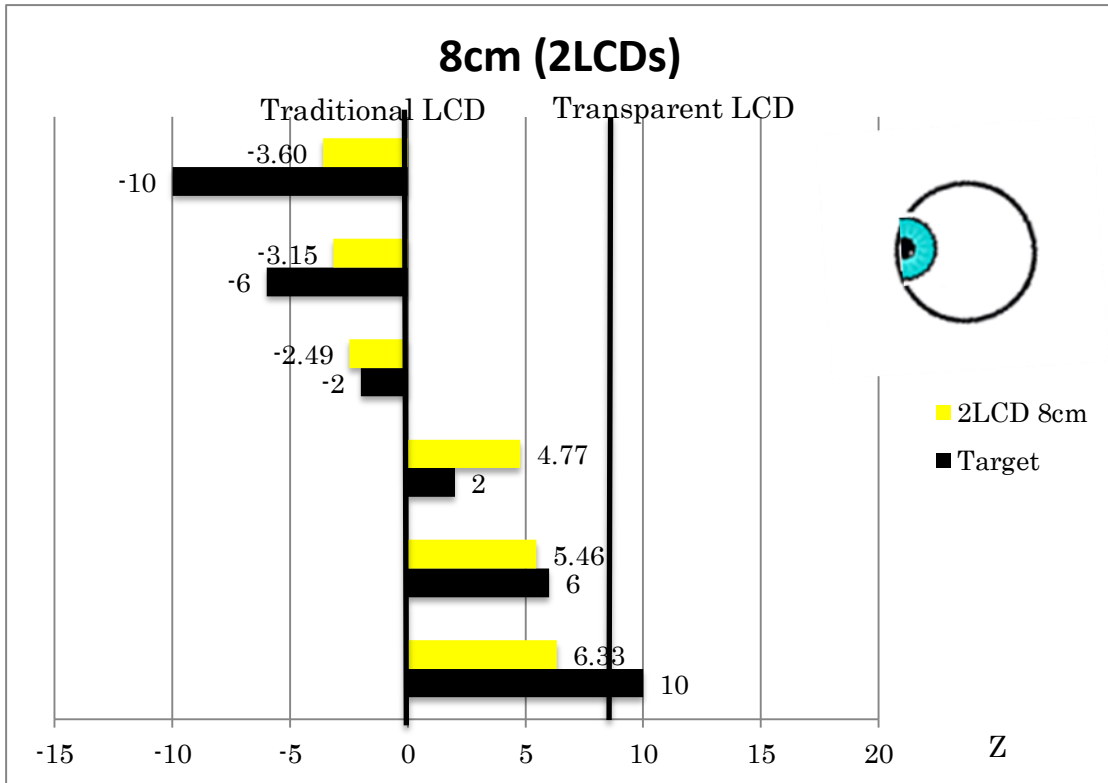

Fig.4-10: Contrast of setting depth and experimenters' perceived depth (8cm, 2LCD)

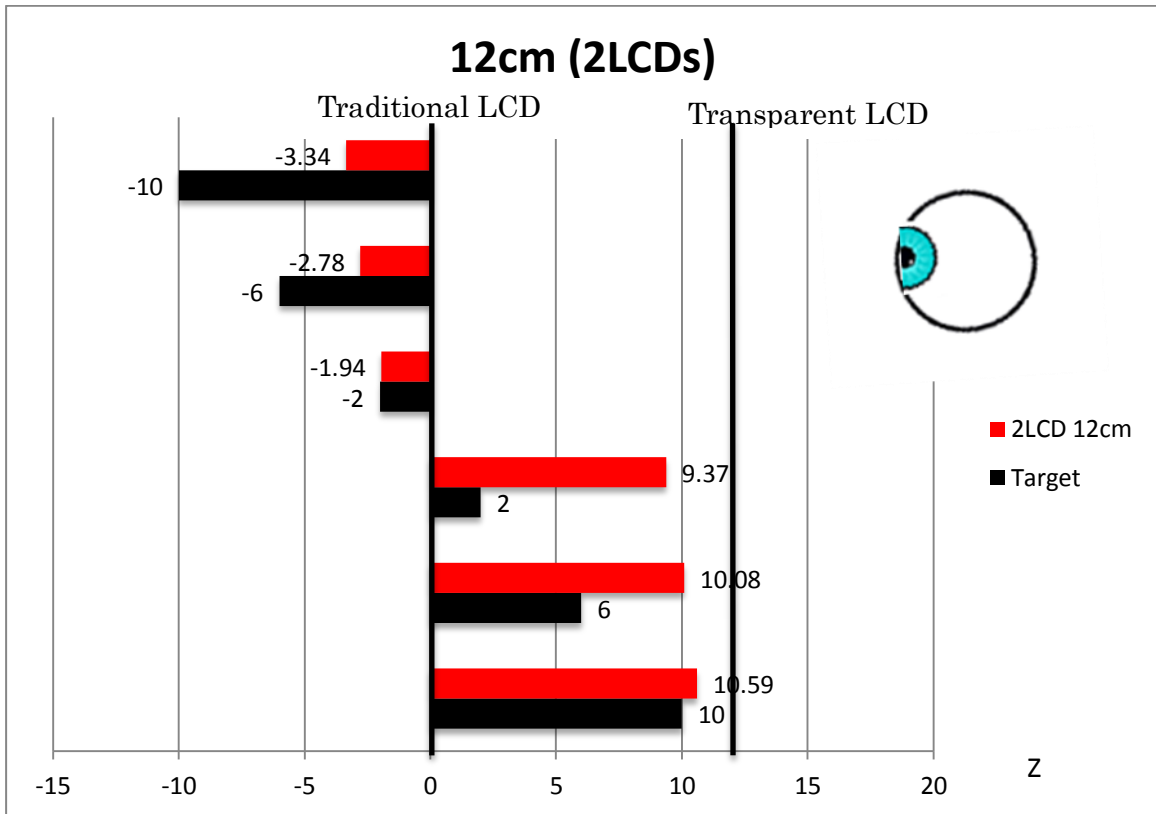

Fig.4-11: Contrast of setting depth and experimenters' perceived depth (12cm, 2LCD)

Figure4-8 shows the situation of only traditional LCD. Through figure4-8, we can find that compared with the setting range of depth, the range of depth that the experimenter perceived is much more narrow. It indicates that even though one LCD can convey a certain depth perception, but it is limited. Another interesting phenomenon we find from figure4-8 is that there are 5 layers which we feel them going backward the traditional LCD. And among these 5 layers, there are actually 2 layers which we set should be in front of the traditional LCD. It seems like instead of feeling the object flying out from the LCD, the feeling of moving backward is much stronger.

Figure4-9, 4-10, 4-11 show the situation of two LCDs. We can find that in the situations of two LCDs, objects are perceived to be in some new positions which are not perceived in the situation of one LCD. And if you pay attention to the front 3 layers, you will find in these situations they are all perceived to be in front of the traditional LCD. It means by using two LCDs, we can make the objects which we thought should be at the back of the traditional LCD in situation of one LCD to fly out to new positions. However, if we compare the front 3 layers in figure4-9, figure4-10 figure4-11 with the transparent LCD correspondingly. We can figure out that in the 3 situations of two LCDs, all the front 3 layers are perceived backward to the transparent LCD. It seems like even for the transparent LCD, the feeling of moving

backward is also much stronger.

Another important point is that if we compare the ranges of the depth we perceived in the situations of two LCDs, you can apparently find the ranges in the situation of two LCDs are much bigger than situation of one LCD. This indicates that the perceived range of depth was expanded by two LCDs. It can be a significant support for that our system can enhance the capability of conveying depth perception comparing with one traditional LCD.

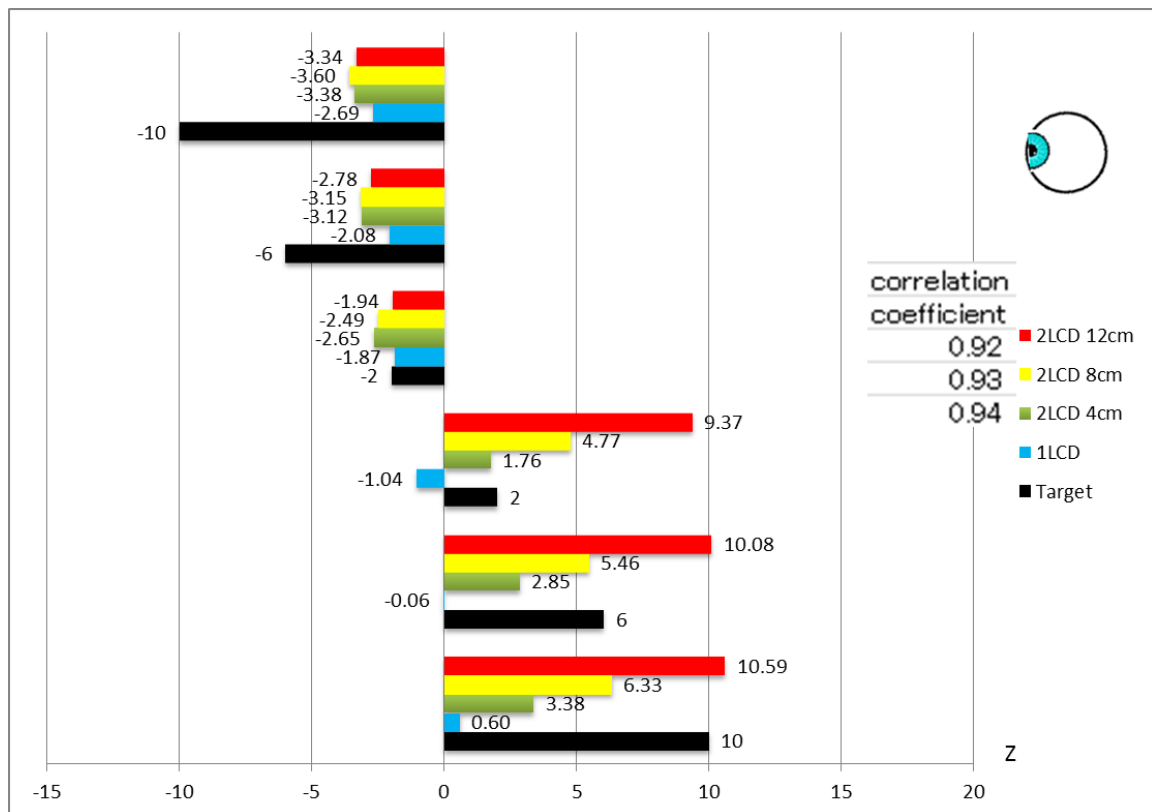

Fig.4-12: Contrast of the 4 situations in MP experiment

Figure4-12 shows the contrast of the 4 situations, and the correlation coefficients of perceived depth and setting depth in the 3 situations of two LCDs. The correlation coefficients are gradually increasing according to the sequence of 12cm (2LCD), 8cm

(2LCD) , 4cm (2LCD) . Considering the experimental error, we may say that 4cm~8cm could be a better interval for the 2 LCDs because that they have higher correlation coefficients with the setting depth.

In conclusion, through motion parallax experiment, we find that each of the two LCD have a certain range around themselves to be able to show 3D effect. Because of this effect, our system expanded the range of depth we perceived, which further supports the hypothesis that our system can enhance the capability of conveying depth perception comparing with one traditional LCD. Moreover, the data indicates that the best interval of the two LCDs should be between 4cm and 6cm.

Nevertheless, the results also reflect a problem. If you pay attention to the depth we perceived for Layer 3 and Layer 4 (middle two layers), you will find there is actually a gap between the two layers which makes the images be not continuous. To solve this problem, we will introduce another method to create 3D sensation in the following chapter.

5 Depth-Fused 3D (DFD) experiment

5.1 Experimental purpose (DFD)

By using DFD (Depth-fused 3D) which is another method to create 3D sensation, we try to solve the problem that there is a discontinuous representation gap between the two LCDs in the last experiment using motion parallax. In this experiment, we will verify the phenomenon of DFD in our system and then explore how the depth perception will be changed by using DFD in a quantitative way.

5.2 Experimental principle (DFD)

The DFD effect was originally found during a study on interpolating the layers of discrete 2D images. Images at intermediate depth can be produced by simply controlling the luminance of two stacked 2D image [Date, 2007]. DFD perception occurs when two 2D images are displayed such that they are superimposed on two transparent screens with varying luminance and the observer perceives a 3D image.

[Lee, 2009]

Figure5-1 explains the fundamental of DFD. In figure5-1 a, in the depth direction as viewed from the observer, there are two 2-D images being displayed on two transparent planes. The two 2-D images are at the same height with our eyes. What

the observer supposes to perceive is actually not 2 separated 2-D images but one fused 3D image in the depth direction. In figure5-1 b, it shows that we can perceive a continuous depth change of the depth-fuse 3D image when the luminance ratio between the two 2-D images at each point is continuously changed according to the distance ratio between the object and the two image planes [Takada, 2006]. The image appears closer to the observer if the front screen is more luminous and farther away if the back screen is more luminous.

(a) Depth-fusing process in ordinary images with edges

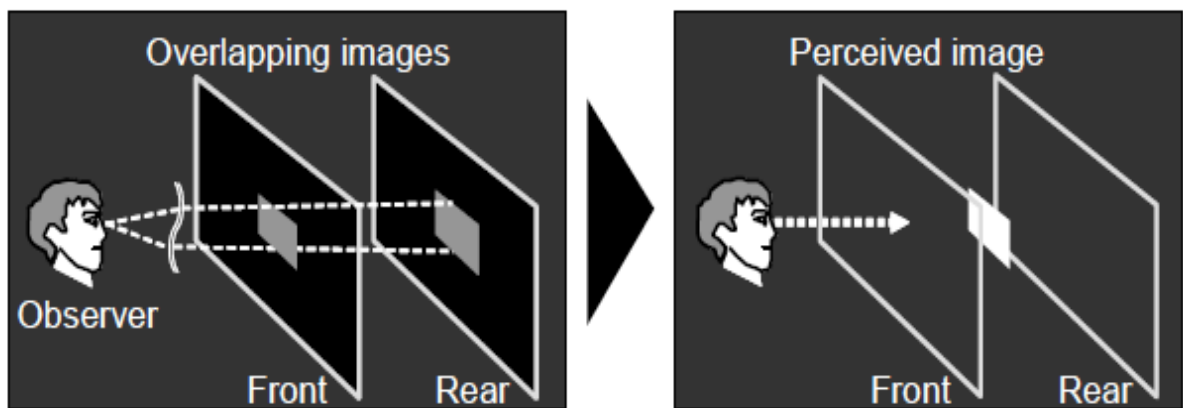

(b) Continuous-depth perception process

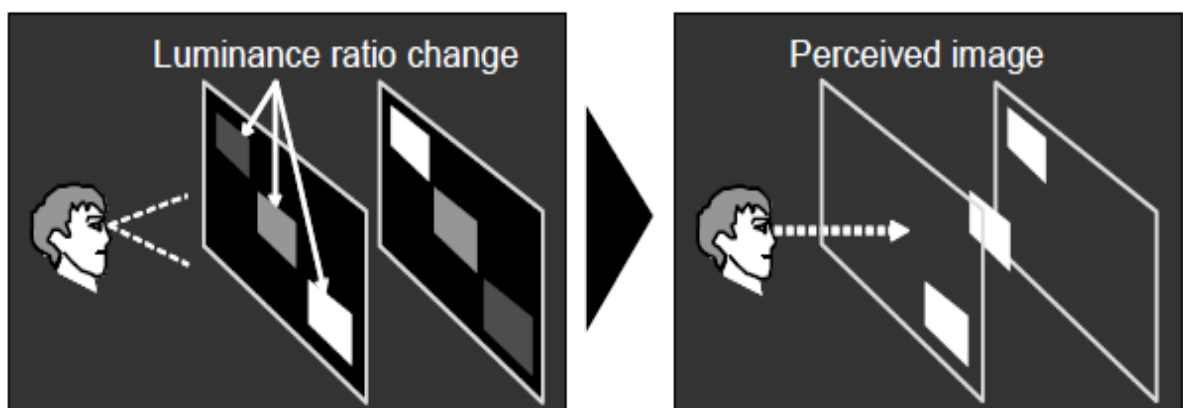

Fig.5-1: Principle of DFD

[Source: Takada, 2006]

5.3 Experimental procedure (DFD)

5.3.1 Preparation (DFD)

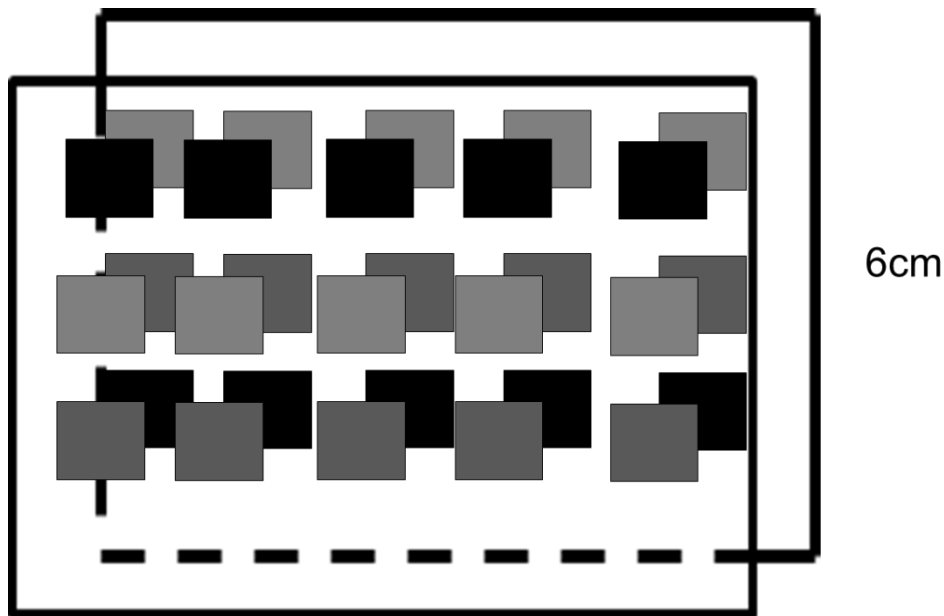

Fig.5-2: Schematic of DFD experiment

Figure5-2 shows the schematic of this DFD experiment. Firstly based on the result from last chapter, we found that the best interval for the 2 LCDs is between 4~8cm. Here we make the interval be 6cm. As Figure shows, we display several lines of squares with different luminance to each LCD. We keep the front and the rear lines of squares being with different luminance. For example we set the front line of squares' luminance to be 80% and set the rear line of squares' luminance to be 20%. Then we overlap the two lines of squares and create the DFD effect. In order to explore how the depth perception will be changed by using DFD in a quantitative way, we tried to test as many combinations of luminance as possible. We designed several

combinations of luminance for the 2 LCDs as Table5-1 shows.

Table. 5-1: Combinations of luminance for DFD experiment

LCD	Luminance Proportion													
	0.0	0.1	0.2	0.3	0.4	0.5	0.6	0.7	0.8	0.9	1.0	0.3	0.7	
Front (Transparent)	0.0	0.1	0.2	0.3	0.4	0.5	0.6	0.7	0.8	0.9	1.0	0.3	0.7	
Rear (Traditional)	1.0	0.9	0.8	0.7	0.6	0.5	0.4	0.3	0.2	0.1	0.0	0.3	0.7	

Both of the two LCDs cover the luminance of 0%~100% at an interval of 10%. And the luminance percentages of the two LCDs are complementary which means the sum of them is 100%. In addition to that, we also want to know what will happen if the sum of luminance percentages is not 100%. So we added the combinations of 0.3/0.3 and 0.7/0.7. We will compare the result of 0.3/0.3, 0.5/0.5 and 0.7/0.7.

However, before we start the DFD experiment, there is still one problem that we have to solve. Because of the different specifications of the two LCDs and the film that we covered on the traditional LCD to eliminate the polarization, actually the color performance of the two LCDs is different. For example, even if we set the same black color (RGB: 0, 0, 0), the front transparent LCD may still look like different color with the rear traditional one. As a result, it is inevitable to make color compensation to keep them have the same standard for color performance. We made a color compensation table as table5-2 shows. Figure5-3 shows the final effect of color compensation, the upper line of squares are displayed on the rear traditional LCD and

lower line of squares are displayed on the front transparent one. The color performance is approximately equal to each other.

Table. 5-2: Color compensation table

Traditional LCD			Transparent LCD		
R	G	B	R	G	B
0	0	0	0.30	0.30	0
0.1	0.1	0.1	0.32	0.32	0
0.2	0.2	0.2	0.34	0.34	0
0.3	0.3	0.3	0.36	0.36	0
0.4	0.4	0.4	0.39	0.39	0
0.5	0.5	0.5	0.43	0.43	0
0.6	0.6	0.6	0.55	0.55	0
0.7	0.7	0.7	0.67	0.67	0.1
0.8	0.8	0.8	0.79	0.79	0.375
0.9	0.9	0.9	0.91	0.91	0.65
1.0	1.0	1.0	1.0	1.0	1.0

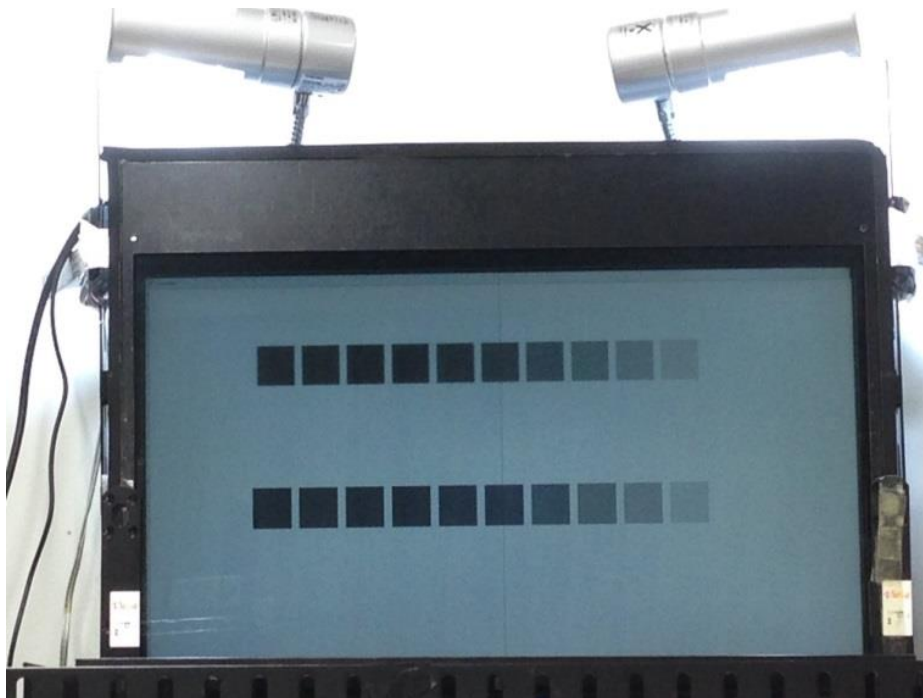

Fig.5-3: Final effect of color compensation

5.3.2 Execution (DFD)

Figure 5-4 shows the scene of DFD experiment. The experimenter sat on the chair in a certain position and put his jaw on the edge of the top part of a tripod which is also fixed in a certain position (2m from the front LCD). Ask him to watch at our system. Then show him the card we prepared and tell him there will be a lot of rectangles which has the same size of this card. But this time they will not move.



Fig.5-4: Scene of DFD experiment

We displayed lines of squares with different combinations of luminance to corresponding LCD. We used the same measurement board that we mentioned in section 3.1 to measure the experimenters' depth perception. And the following experimental procedures were the same as mentioned in the Section 4.3.2.

5.4 Experimental result (DFD)

Totally we had 10 people do the experiment. And for each person we tested 3 patterns of images (changing the sequence in the depth direction). Figure5-5 shows the average results and the standard deviation of the 10 people. X axis represents the combinations of luminance of rear and front LCD. Y axis represents the perceived depth (Z coordinate).

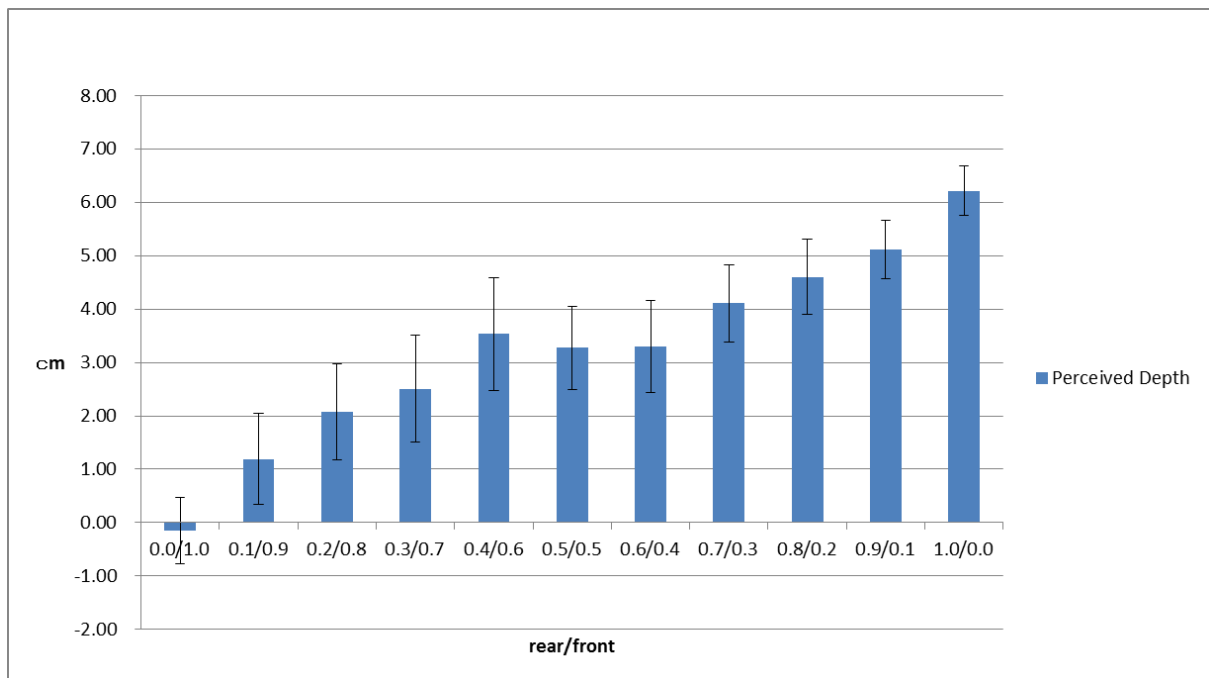

Fig.5-5: Average result and variance of 10 people for the DFD experiment

Firstly we should make sure that whether different combinations of luminance will result in different perceived depth or not. So we held the analysis of variance (ANOVA) test to check the significance level of our data. In table5-3, it shows that the significance level (Sig) is under 0.05. It is indicated that there is statistical

significance in different combinations of luminance, which proves that combinations of luminance has different influence on the experimenters' perceived depth.

Table. 5-3: ANOVA for the data of DFD experiment

	Sum of Squares	df	Mean Square	F	Sig.
Between Groups	326.698	10	32.670	51.963	.000
Within Groups	62.242	99	.629		
Total	388.940	109			

To have a better analysis for the data. We made figure5-6 which shows the data in a more intuitional way. We also draw a regression curve () based on the data.

$$y = 0.0153x^3 - 0.2883x^2 + 2.0687x - 1.9372 \quad (5-1)$$

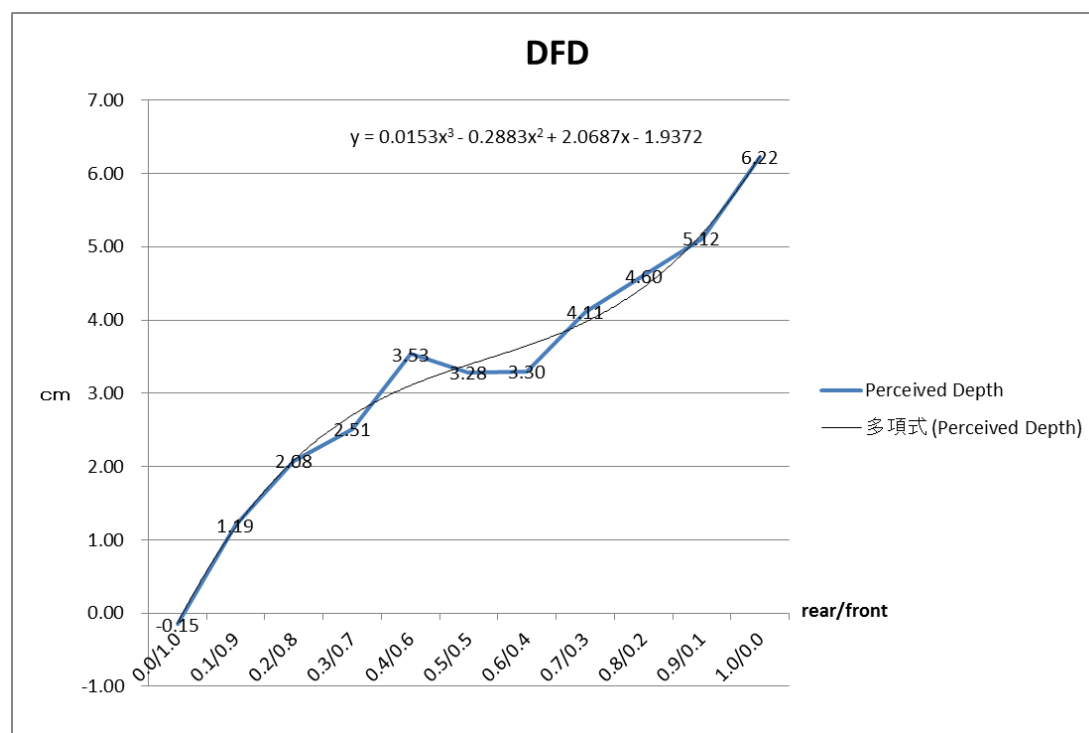

Fig.5-6: Regression curve of the data for the DFD experiment

Focusing on the regression curve which indicates the trend of perceived depth, we can find that as the combinations of luminance changes the perceived depth also changes. The image appears closer to the observer if the front LCD is more luminous and farther away if the back LCD is more luminous. For example, the result for combination of 0.2/0.8 is around 2.0cm (away from the traditional LCD), on the other side, the result for combination of 0.8/0.2 is around 4.5cm (away from the traditional LCD), which appears closer to the observer. And the curve continuously crosses the whole interval between the two LCDs, making the discontinuous part be filled up. We have successfully verified the DFD phenomenon by our layer 3D display system. We also tested the situation that the sum of luminance percentages is not 100%. Figure5-7 is the result of this situation. We can see the results for the three kinds of

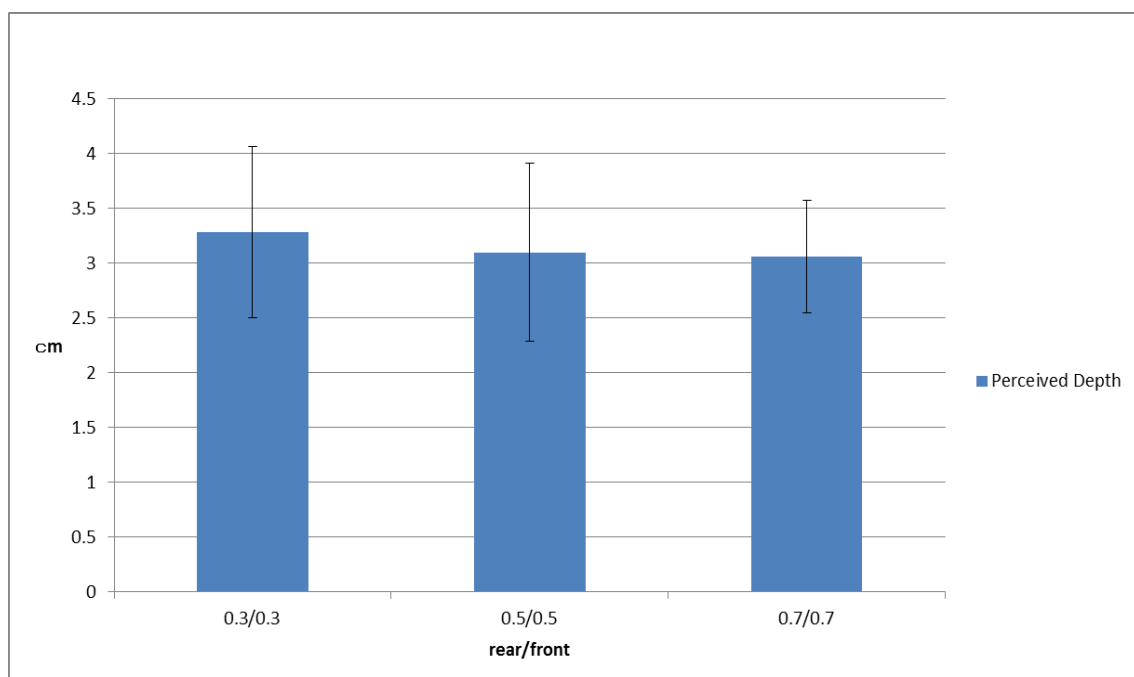

Fig.5-7: Result of the situation that the sum of luminance percentages is not 100%.

combinations are all around 3cm (away from the traditional LCD). We also analyzed the statistical significance of the data for three combinations. Table5-4 shows that the significance level (Sig) is above 0.05 which means there is no statistical significance among the three kinds of combinations. From the data we can say that if the proportion of luminance is the same, no matter the sum of the luminance percentages is 100% or not, there will be same effect on the perceived depth.

Table. 5-4: ANOVA the situation (sum of luminance percentages is not 100%)

	Sum of Squares	df	Mean Square	F	Sig.
Between Groups	.824	2	.412	.621	.540
Within Groups	57.720	87	.663		
Total	58.544	89			

In conclusion, through DFD experiment, we successfully verified the DFD phenomenon in our system and found that we can smoothly fill up the discontinuous interval between the two LCDs which had been a problem in the last motion parallax experiment. We also deduced one regression curve to be a reference for how we can realize a certain depth perception by using DFD in a quantitative way. For the problem that whether the sum of luminance percentages is 100% will have different

influence on perceived depth, our data shows that there is no significant difference..

Until now we have finished the motion parallax and DFD experiment respectively. We have found the way to create 3D effect around the two LCDs and between them. What effect will we get if we combine these two methods together? We will introduce that in the following chapter.

6 Motion parallax and Depth-fused 3D experiment

6.1 Experimental purpose (MP+DFD)

By combining motion parallax and DFD, we try to fuse the range (around the two LCDs) where can represent the 3D effect by using motion parallax and the range (between the two LCDs) where can represent the 3D effect by using DFD. We want to verify that whether the two methods of creating 3D can integrate the space outside the two LCDs and between them, and make it possible to convey 3D sensation.

6.2 Experimental procedure (MP+DFD)

6.2.1 Preparation (MP+DFD)

Figure6-1 shows the schematic of this combination experiment. We still keep the interval of the two LCDs be 6 cm. Here we have 6 lines of squares with 6 different z coordinates of -2, 0, 2, 4, 6 and 8. The traditional LCD is at the position of $z=0$ and the transparent LCD is at the position of $z=6$. For the middle two lines of squares which are in the yellow frame, we applied DFD. And we made all the 6 lines of squares in the green frame do the same horizontal moving like we did in the motion parallax experiment, which means we applied motion parallax to all of them.

Figure6-2 gives an example of the images displayed on the two LCDs for this experiment. As you can see that the upper two lines are being displayed only on the

rear LCD, the lower two lines are being displayed only on the front LCD, and the middle two lines are being displayed on both of the two LCDs with different luminance.

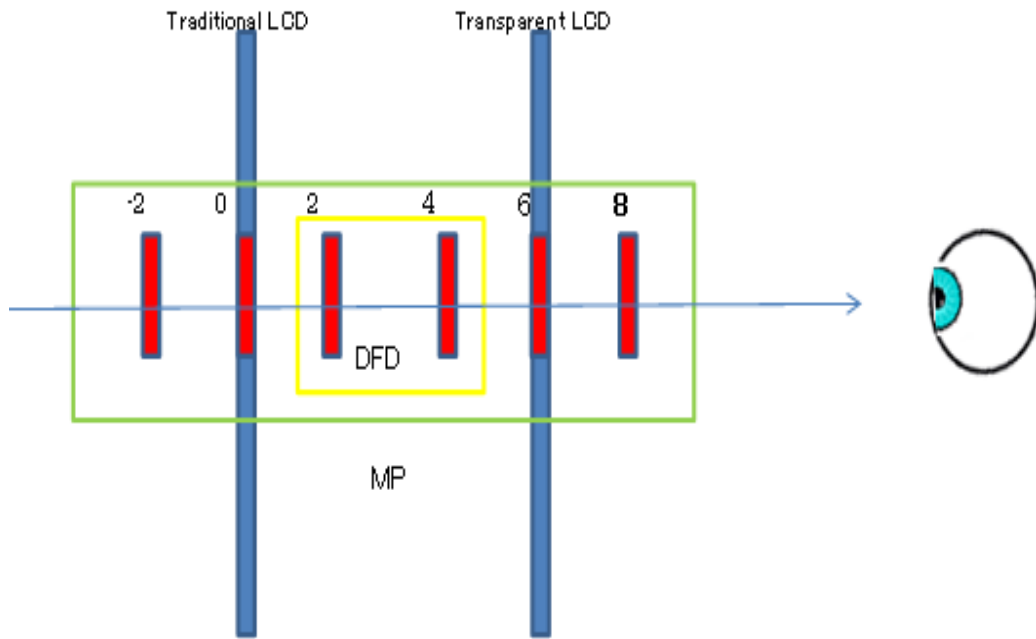

Fig.6-1: Schematic of MP+DFD experiment

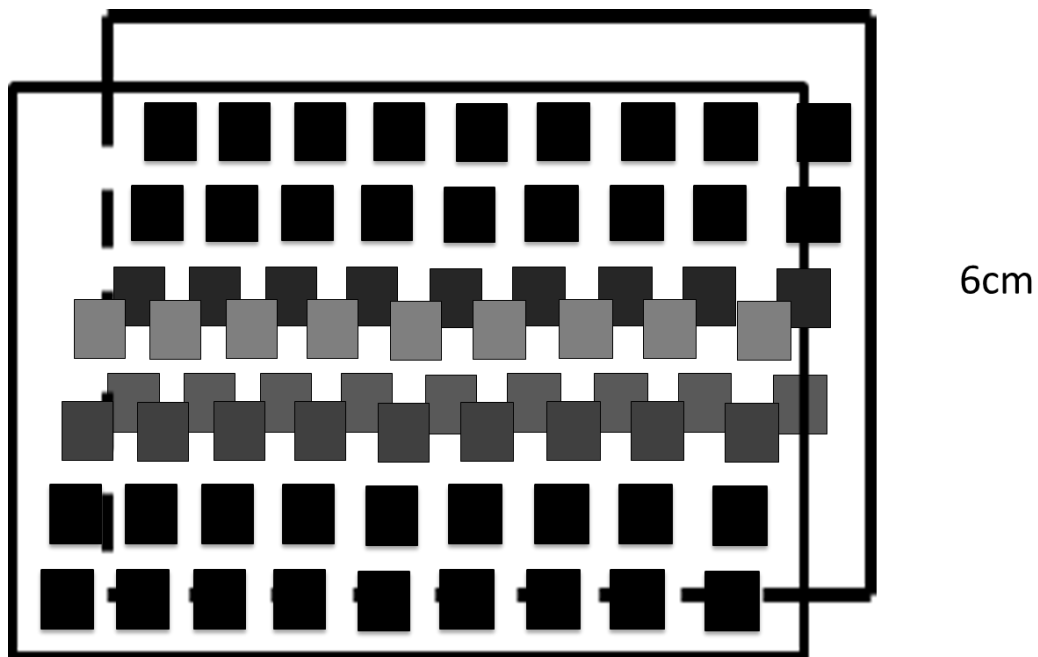

Fig.6-2: Image of MP+DFD experiment

In addition, because we want to apply DFD, we have to think about the color. For the upper two lines and the lower two lines, we made them be black based on the color compensation table 5-2 in Chapter 5. For the middle two lines, we have to decide the luminance combinations to make them approach to the positions of $Z=2$ and $Z=4$. From the regression curve which indicates the trend of perceived depth in Figure, we found that the luminance combinations for the positions of $Z=2$ and $Z=4$ should be 0.2/0.8 and 0.7/0.3 (rear/ front).

6.2.2 Execution (MP+DFD)

On the whole, we used the same measurement method as we did in the Chapter 4 and 5. We measured all the 6 lines of squares' perceived depth.

6.3 Experimental result (MP+DFD)

Totally we had 10 people do the experiment. And for each person we tested 3 patterns of images (changing the sequence in the depth direction). Figure 6-3 shows the average result and figure 6-4 shows the variance of the data. Figure 6-3 is also the side view of our system, the horizontal axis shows the perceived depth of the lines and the longitudinal axis shows the vertical position of the lines. The red bar is the target depth we set in the program and the blue bar is the real perceived depth by the experimenters.

From figure6-3, we can see that from the left to the right, the values of the blue bars tend to be continuously and smoothly increasing. And the perceived depth cover the

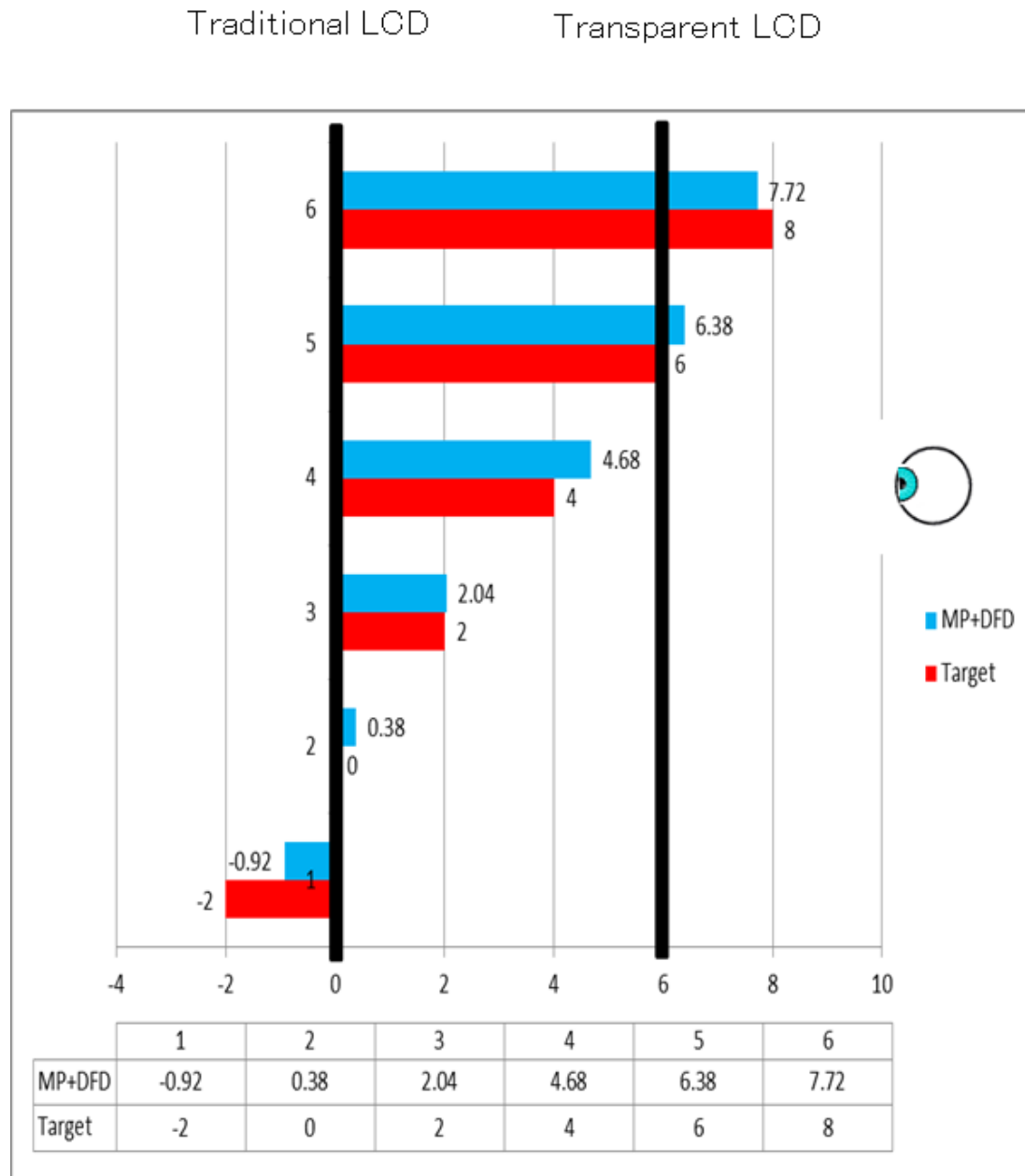

Fig.6-3: Average result of 10 people for the MP+DFD experiment

area from $z=-0.92$ to $z=7.72$. It indicates that we successfully integrated the space outside the two LCDs and between them. For some lines of squares, the experimenters had a feeling of flying out from our system. For some lines of squares,

the experimenters had a feeling of moving to the back side of our system. For some lines of squares, the experimenters had a feeling of existing between our two LCDs. We have made both the range around our two LCDs and the range between them able to convey the depth perception simultaneously.

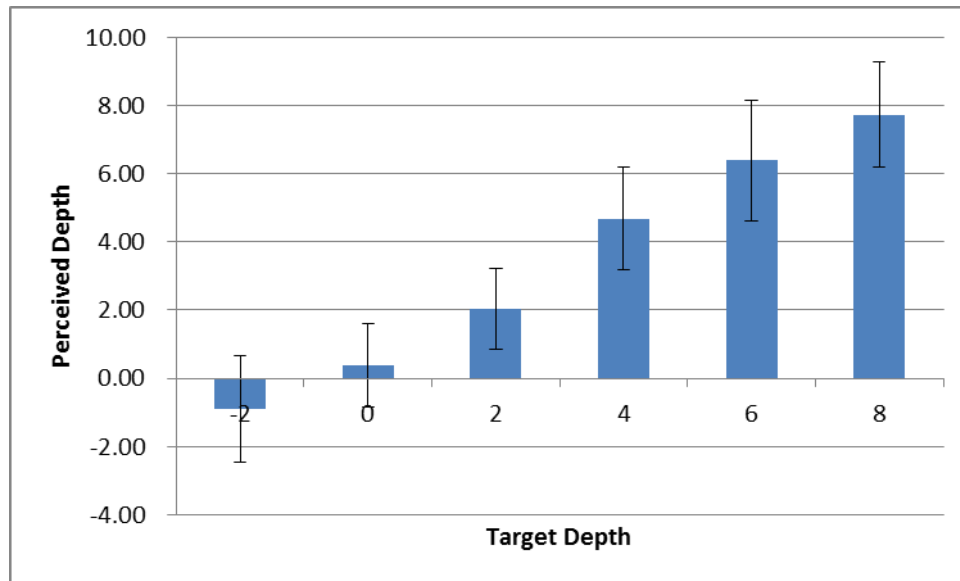

Fig.6-4: Variance of the data for the MP+DFD experiment

Through this motion parallax and Depth-fused 3D experiment, we know that it is possible to make the depth perception more smooth and continuous by combining the two methods of creating 3D effect in our system.

7 Application example

Through the three experiments in chapter 4, chapter 5 and chapter 6, we have found that the combination of motion parallax and Depth-fused 3D is a valid way to create 3D effect in our layer 3D display system. In this chapter, we will introduce one application example and discuss about the feedback from people who have watched that.

We used one of the famous Japanese traditional paintings called Ukiyoe as our application example. Figure7-1 shows the schematic diagram of how we displayed Ukiyoe in our layered 3D display system. Firstly, as shown in Figure7-1, we separated Ukiyoe into five layers of pictures based on the depth of different objects. We displayed the first three layered onto the front transparent LCD and the last three layered onto the rear traditional LCD as shown in figure7-2. Then we simulated the movement of our eyes to make the five layered do horizontal moving, which means conducting motion parallax. For the middle layer (No. 3), because it is displayed both on the two LCDs and with the same luminance, based on the result of DFD experiment, it should be perceived just in the middle of the two LCDs. Combined with the effect of motion parallax, the five layers of pictures will finally be presented in a stereoscopic way as shown in figure7-2. As a comparison, we also displayed all

the five layers on the traditional LCD and simulated the same eye movement as figure7-3 shows.

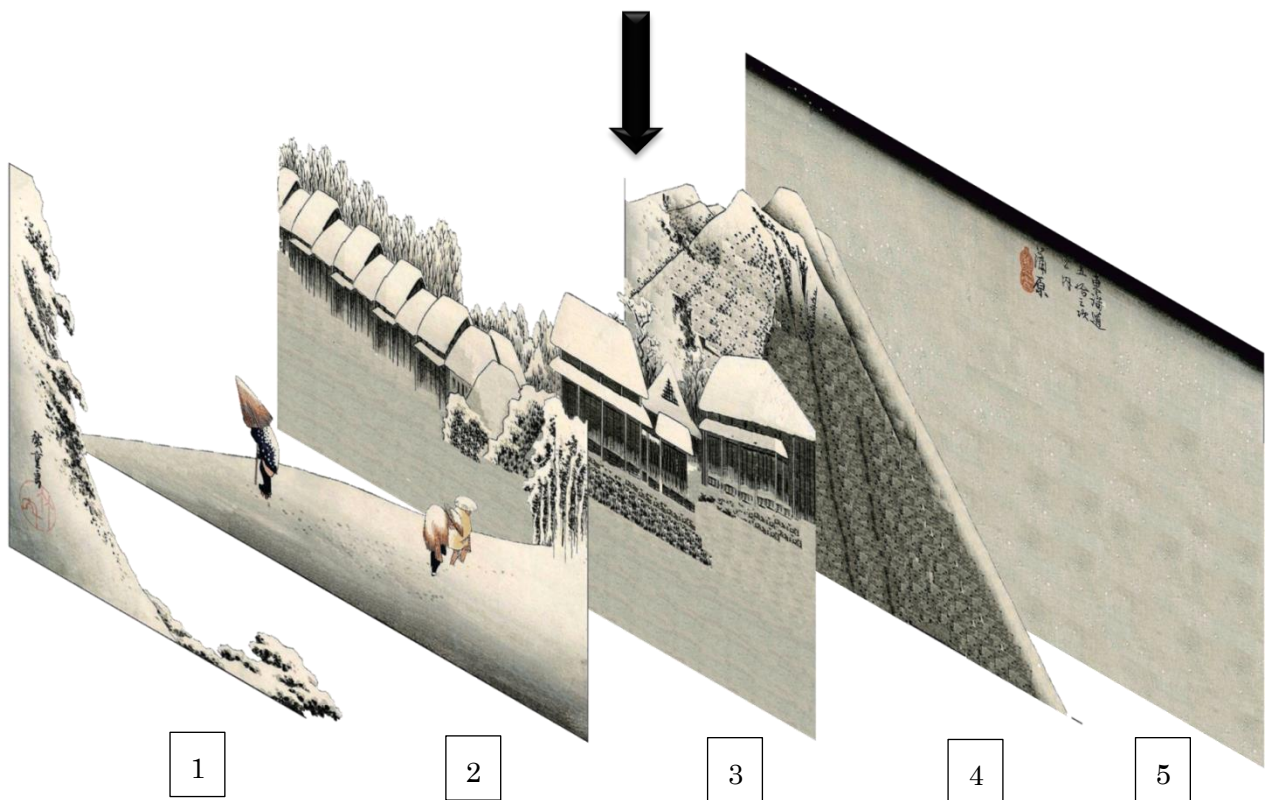

Fig.7-1: Separation of Ukiyoe

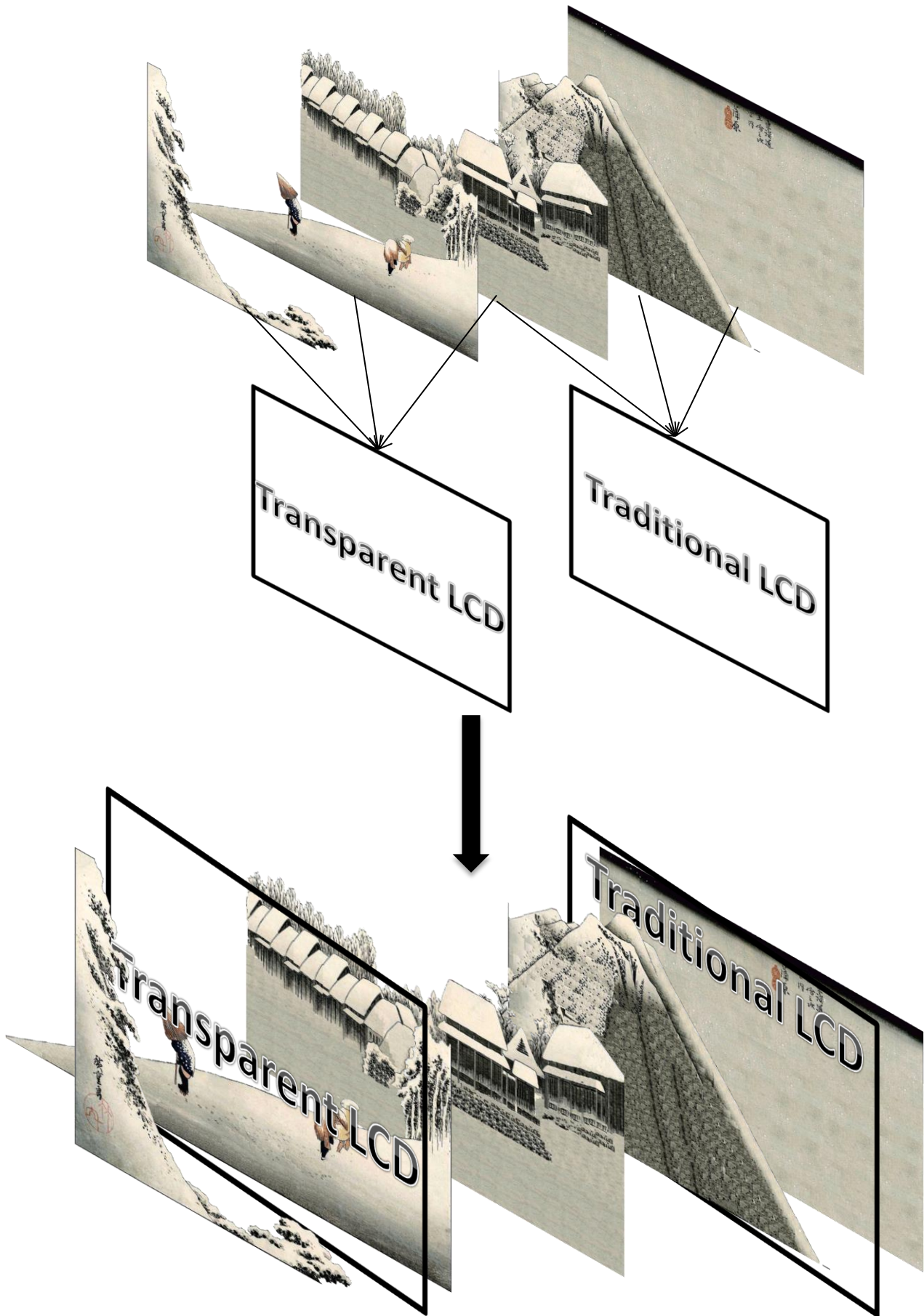

Fig.7-2: Schematic diagram of displaying 3D Ukiyoe in 2 LCDs

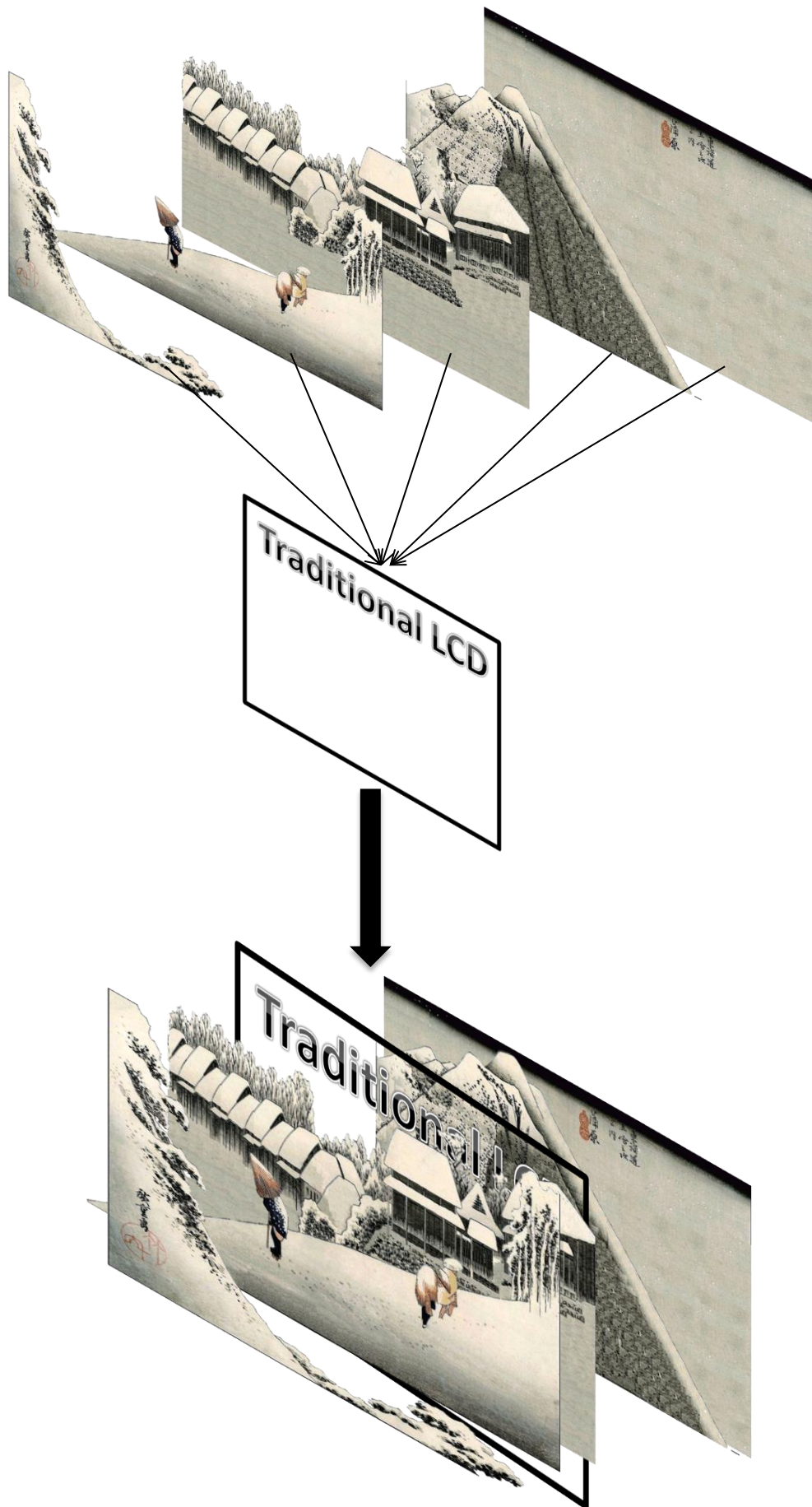

Fig.7-3: Schematic diagram of displaying 3D Ukiyoe in 1 LCD



2 LCDs



1 LCD

Fig.7-4: Real pictures of Ukiyoe in two situations

It is hard to tell the difference between these two situations by the 2D pictures. Let's pay attention to the feedbacks from 10 experimenters. We made a questionnaire as follows. Here we will show the results from 10 experimenters with the questionnaire together.

Questionnaire

You will see two short videos, please pay attention to the sense of depth and answer Q1~Q4 by comparing the two videos. (Video1: 1 LCD, Video2: 2 LCDs)

Question 1

If the range of depth perception in the Video1 is 10, how much do you think it should be in Video2? (Examples: 2 times—20, half—5)

Answer 1:

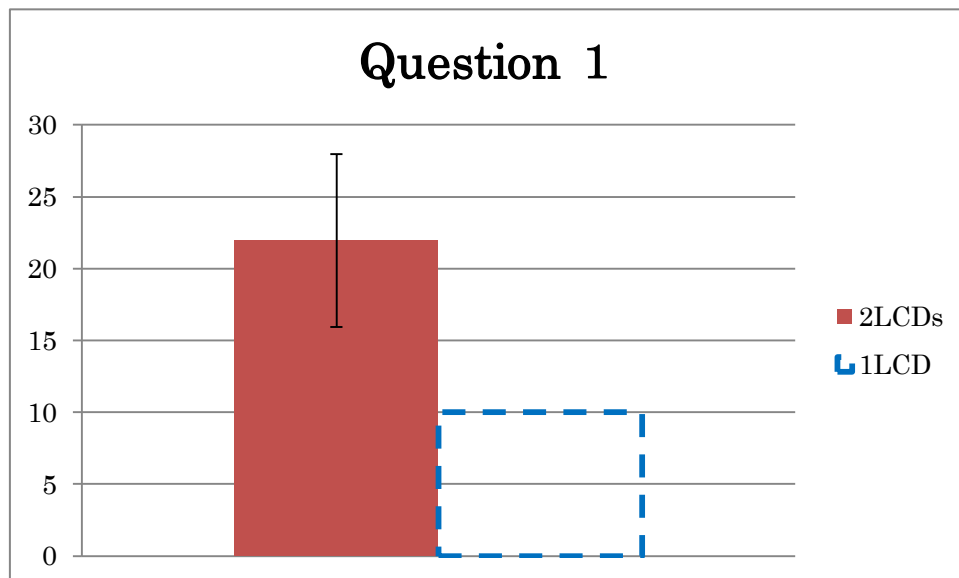

Fig.7-5: Result of Q1

Question 2

Between the object that you think farthest away from you and the object that you think nearest to you, how long do you think the distance should be? Please choose the closest answer for each video.

2cm, 4cm, 6cm, 8cm, 10cm, 12cm, 14cm, 16cm, 18cm, 20cm, 22cm, 24cm, above

Answer 2:

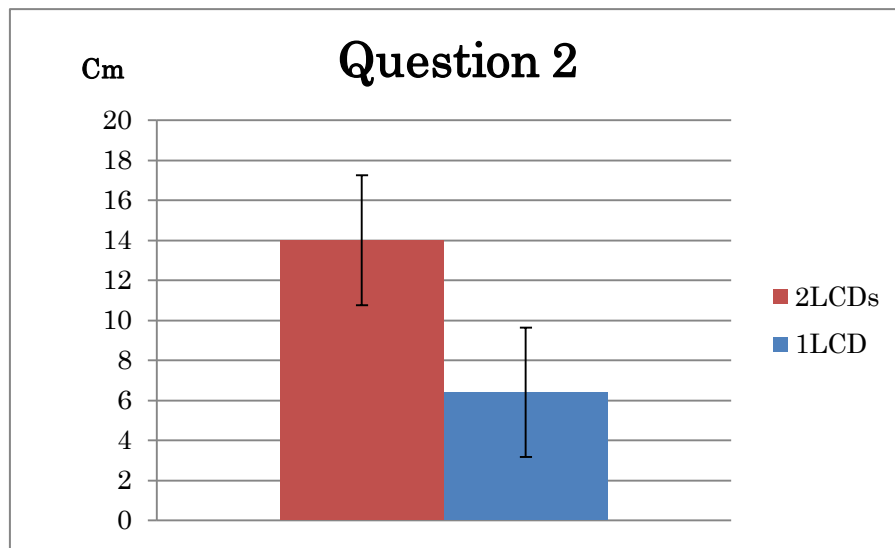

Fig.7-6: Result of Q2

Question 3

How many layers in the depth direction do you think there are? Please choose the closest answer for each video.

1, 2, 3, 4, 5, 6, 7, 8, 9, 10, Above

Answer 3:

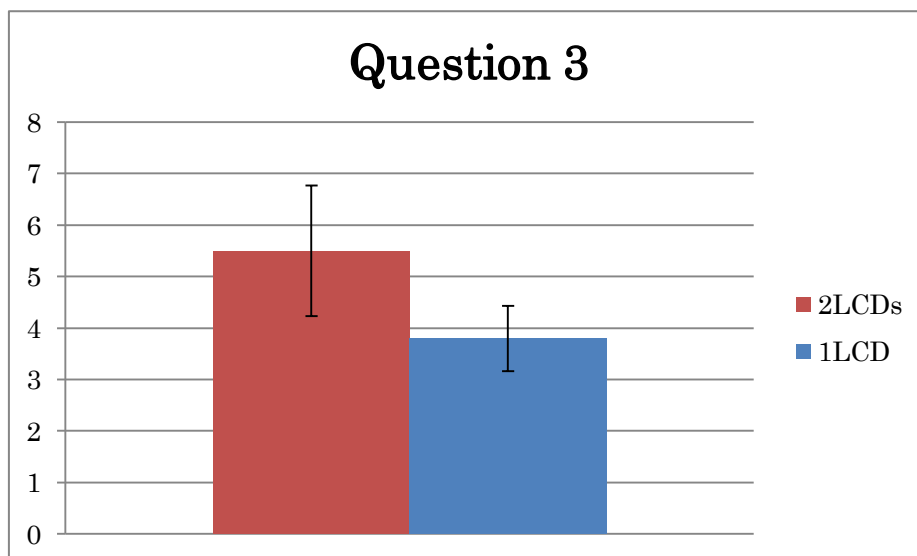

Fig.7-7: Result of Q3

Question 4

How do you think the 3D sensation of the two videos? Example: if strong, please choose 5.

5. Strong 4. Slightly strong 3. Normal 2. Not very 1. Not at all

Answer 4:

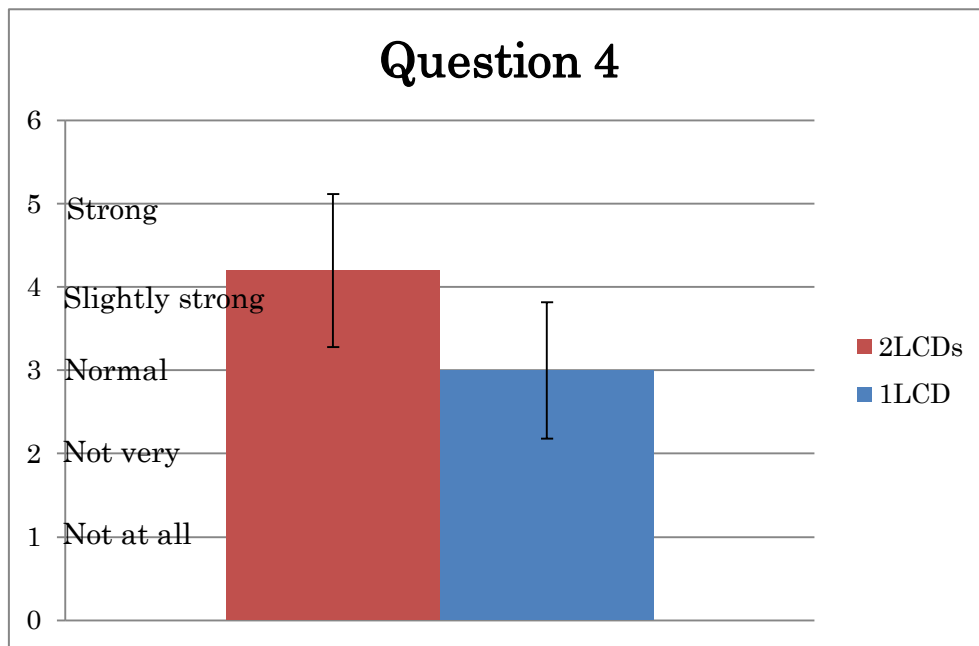

Fig.7-8: Result of Q4

Result of Q1 and Q2 shows that the range of depth perception of our layered 3D display system is over 2 times larger than the situation of one LCD. And from result of Q2, we can also find that the average distance between the perceived farthest object and the perceived nearest object is around 14cm, which is much bigger than 6cm (the interval of the two LCDs). This result is identical with what we proved in the previous chapters. Comparing with one traditional LCD, our system has apparently enhanced

the capability of conveying depth perception. Furthermore, from result of Q3, we can find another interesting thing. In the situation of two LCDs, averagely the experimenters can figure out more than 5 layers. However in the situation of one LCD, they can only figure out less than 3 layers. This result indicates that our system even increased the resolution of depth perception. And lastly, result of Q4 shows the difference of overall 3D sensation in the two situations. Most of the experimenter thinks that our system has a comparatively strong 3D sensation. On the other hand, most of them think that one LCD's 3D sensation is just normal.

Through this Ukiyoe example, the experimenters admitted the 3D performance of our layered 3D display system.

8 Discussion

In this chapter, we will discuss the future issues and future prospects of our system.

Until now in all the experiments that we have conducted, we simulated the eye movement when adding motion parallax. In that situation, our viewpoint was fixed.

However in fact, it is possible to realize free viewpoint in our system. Figure8-1 introduces one possible way by using Kinect. Kinect is a device developed by Microsoft, which can detect the motion of humans by collecting the depth information.

By using Kinect, we can trace the movement of our eyes and make the contents in our

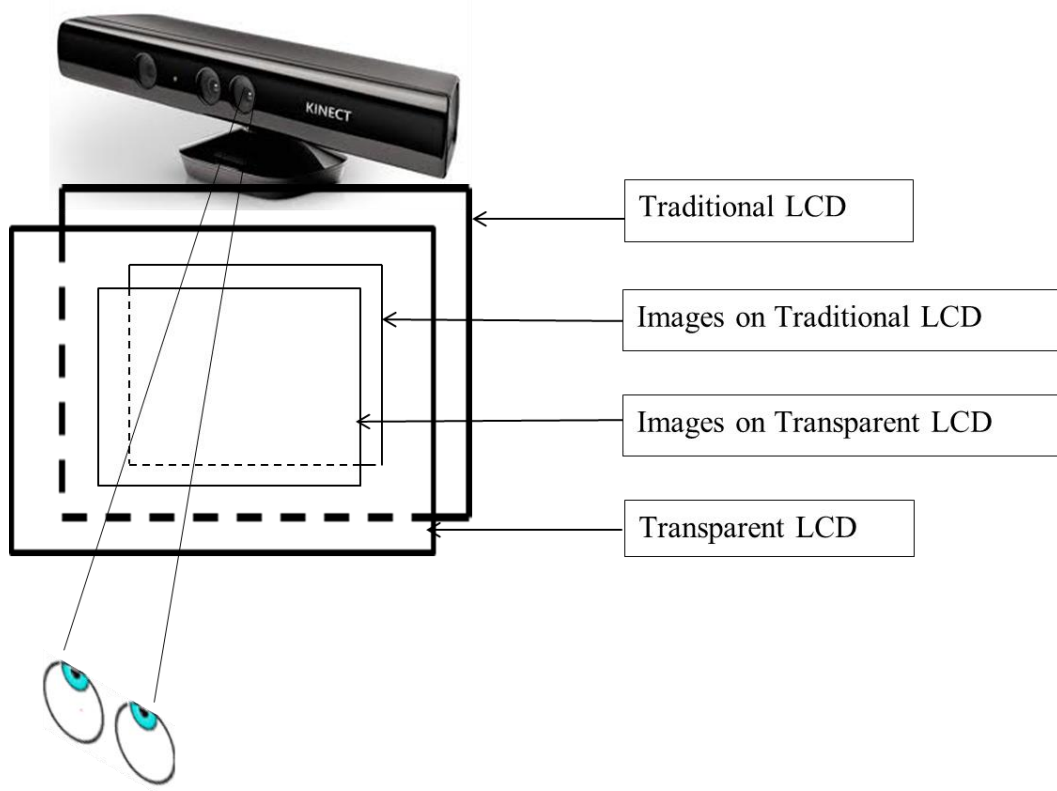

Fig.8-1: An idea to realize free viewpoint for our system in the future

system able to change as our viewpoint changes. If this idea is realized in the future, our system will become a more free style 3D system.

Another issue is about the color. As we know that the transparent LCD is still not a mature product yet. There are some still problems or technical restrictions. One of the problems we care about is the color performance. As you can see in figure7-4, even though we present better 3D effect by using our system, the color performance is not so perfect. Because the transparent LCD only has 16.7M display colors, inevitably there will be influence on restoring the color. Nevertheless, we believe that as the technology of transparent LCD develops there will be much high quality transparent LCD coming soon in the future. The problem of color distortion will be solved.

And we also believe that the transparent rate will be also increased in the future. If we have better transparent rate, we can even expand our system to be like figure 8-2. We can add the number of transparent LCDs and make the depth perception more excellent.

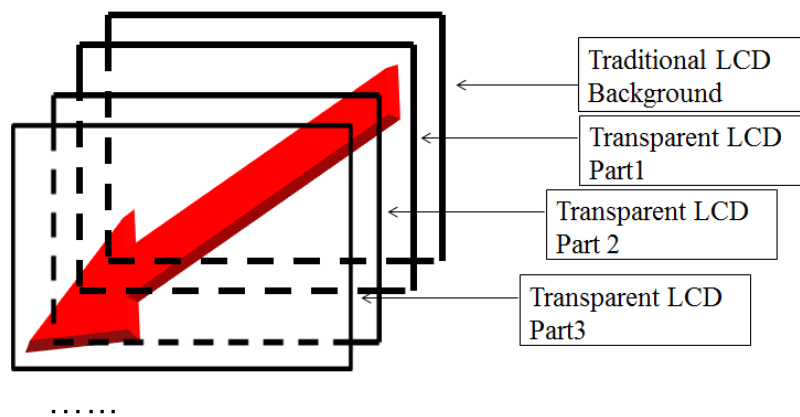

Fig.8-2: Image of an advanced layered 3D display system

9 Conclusion

In this research, concerning the problems of current 3D display system, we proposed and successfully built a new layered 3D display system by combining the transparent LCD and the traditional LCD. Based on the special structure of our system, we put forward two methods (motion parallax and DFD) to realize 3D effect. We made the experiments to prove the feasibility of the two methods in our system and the application example to evaluate the 3D performance of our system.

Through a large number of experiments, we have obtained several significant conclusions. Firstly, the combination of motion parallax and DFD is a valid method to create 3D effect in our system. Secondly, through the combination of motion parallax and DFD, we successfully expanded the range of depth perception and increased the resolution of depth perception comparing with the situation of one traditional LCD. And finally, from the feedback from experimenters, the overall 3D performance of our system has been highly evaluated.

All in all, we have successfully built a simple structured layered 3D display system which does not need any additional device at a reasonable cost. And we have proved the 3D performance of this system.

Acknowledge

First of all I would like to thank Professor Ogi Tetsuto, my supervisor. He has provided me with an incredible amount of knowledge, advices and encouragement over my two years in Keio University. Professor Ogi guided me step by step and provided me with countless suggestions regarding the direction and contents of my research. I am very grateful for his patience and understanding.

I would like to thank the former associate teacher Tateyama Yoshisuke for his supports. He gave me great help especially in the programming part of my research. I am very grateful for his enthusiastic attitude.

I would also like to thank associate Professor Ioki Makoto, my secondary supervisor. Professor Ioki provided me with advices on the logic of my research. I am very grateful for his precious advices.

I would then like to thank my fellow classmates, for their assistance, and encouragement. Especially Leo and Rob, they have helped the experiments for me for countless times and give me incredible amount of advices.

I would also like to thank the members in Ogi laboratory and students in SDM who tested my system, took my questionnaire, and provided useful feedbacks and suggestions.

Finally, I want to thank my families who have kept supporting me for these two years.

Reference

Date, M., & Takada, H. (2007). Small-Depth-Error Display Using Depth Fused 3D (DFD). *Taiwan-Japan Joint Conference on Communications Technology 2007*.

Display Bank. (2011). *Transparent Display Technology and Market Forecast*.

Gabor, D. (1948). A new microscopic principle. *Nature*, Vol. 161, pp. 777-779.

Kim, H. (2010). *Trend and Prospect on 3D Industry and R&D*. Hyundai IT Corporation.

Lee, C., DiVerdi, S., & Hollerer, T. (2009). Depth-Fused 3D Imagery on an Immaterial Display. *IEEE Transactions On Visualization And Computer Graphics January/February 2009*, VOL. 15, NO. 1.

Ohkoshi, T. (1980). Three-dimensional displays. *Proceedings of the IEEE*, Vol. 68, No. 5, pp. 548-564.

Qian, N. (1997). Binocular Disparity and the Perception of Depth. *Neuron*, 18, 359-368.

Segal, M., & Akeley, K. (2010). *The OpenGL Graphics System: A Specification*. The Khronos Group Inc.

Suyama, Y. I. (2004). Apparent 3-D Image Perceived from Luminance-Modulated Two 2-D Images Displayed at Different Depths. *Vision Research*.

Takada, H. (2007). *Research on Clarification of Depth-Fused 3-D Visual Illusion and its Application to 3-D Display*. Waeda Univeristy.

Takada, H. S. (2006). Front and Rear Image Generation Module for Depth-fused 3-D Display. *IEEE Transactions on Consumer Electronics, AUGUST 2006*, Vol. 52, No. 3.

Travis, A. (1997). The display of three-dimensional video images. *Proceedings of the IEEE*, vol. 85, pp. 1817-1832.

Yokozawa, K. (2010). *Visual Science*. Keisoshobo Co.Ltd.

Conference attendance

1. Di Xiong, Yoshisuke Tateyama, Tetsuro Ogi: Layered 3D Display System Based on the Combination of Transparent LCD and Traditional LCD, Design Engineering Workshop in Kitakyushu, 2013
2. Di Xiong, Yoshisuke Tateyama, Tetsuro Ogi: Depth Representation in Layered 3D Display Using Transparent LCD, Tele-Immersion Technology Committee, The Virtual Reality Society Japan, 2014

Appendix

In the discussion part, we have discussed an idea of adding Kinect to realize free viewport in our system. After finishing the main body of this thesis, we actually continued to make a progress. We made a prototype of the idea.

First using Kinect SDK, we made an application to detect the position of people's eye (EYE_X, EYE_Y, EYE_Z). Then we send the position to our original system by using UDP. We replace the eye position (EYE_X, EYE_Y, EYE_Z) that we mentioned in the software design part in chapter3. As a result the movement of the objects in our system will reflect the movement of people's eye movement.

Here we will show the example of Ukiyoe system attaching Kinect.

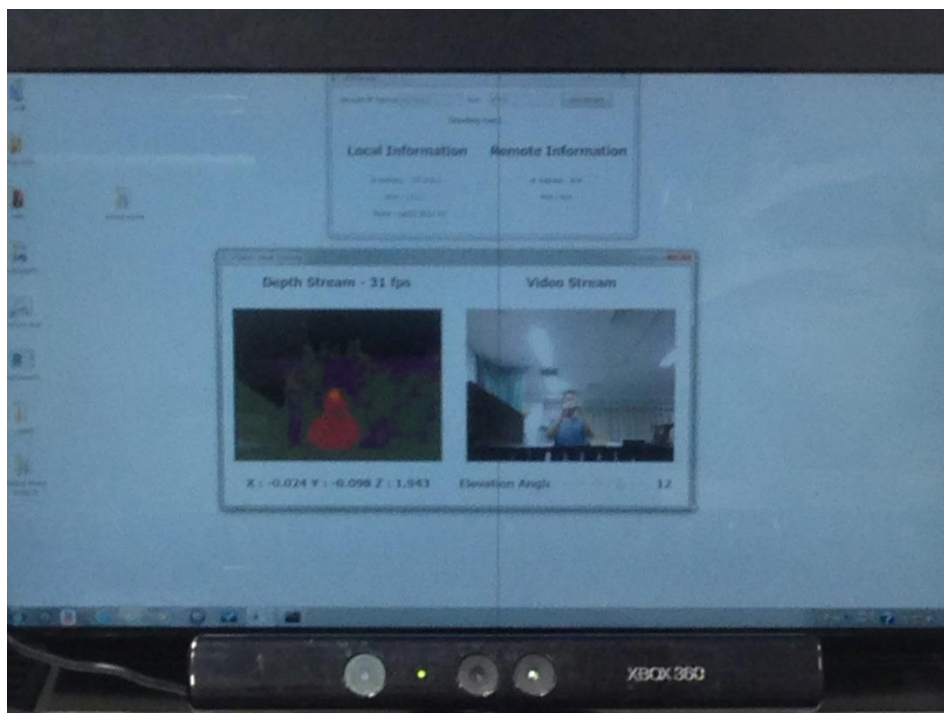

Fig.A-1: Design of eye detection application by Kinect



Fig.A-2: Ukiyoe system with Kinect

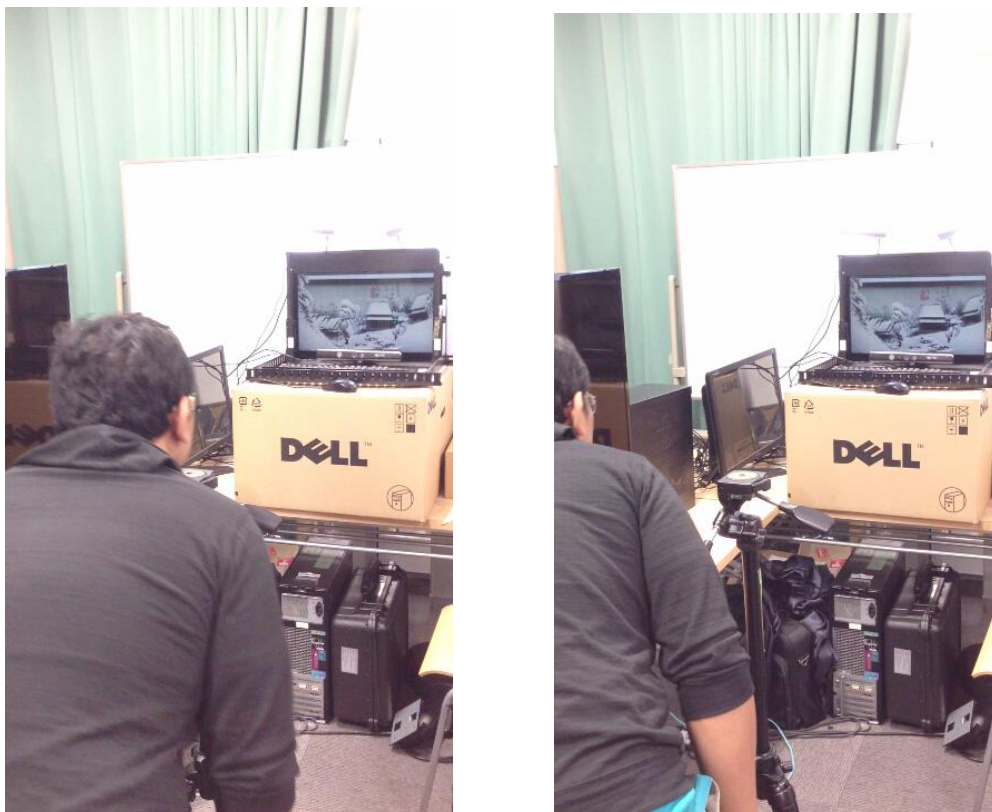

Fig.A-3: Test scene of Ukiyoe system with Kinect (1)



Fig.A-3: Test scene of Ukiyoe system with Kinect (2)



Fig.A-4: Test scene of Ukiyoe system with Kinect (3)